

MS-6/2009
Model Specification and Checklist for
Polyethylene (PE) Pipe for the
Sliplining of Sewers

The Plastics Pipe Institute

March 2009

MS-6/2009 Model Specification and Checklist for Polyethylene (PE) Pipe for the Sliplining of Sewers

DISCLAIMER

This guideline has been prepared by the Plastics Pipe Institute (PPI) for educational purposes and is offered in good faith as a service to the industry. While all information in this guideline is believed to be accurate at the time of its publication, it is offered without warranty of any kind, either expressed or implied (including warranties of merchantability and fitness for a particular purpose). If additional or more detailed information is needed, particularly of unusual or special applications, the pipe supplier or manufacturer should be contacted. The Plastics Pipe Institute and its members accept no responsibility for any loss or damage arising from its use. The Plastics Pipe Institute does not endorse the proprietary products or processes of any manufacturer, and assumes no responsibility for compliance with applicable laws and regulations.

INTRODUCTION

To properly prepare a specification for a sliplining project, information on the project must be collected. The checklist is intended to be a starting point and is designed to help collect the information needed to specify the PE liner for a project.

CHECK LIST

1. Select a pipe liner diameter.

For a sliplining project, the first step is to verify the inside diameter of the existing pipe. Also determine the type of pipe to be sliplined. This information is necessary to select the liner size.

As a rule of thumb, when sliplining, the liner should be about 10% smaller than the existing pipe to insure that the liner will fit inside the existing pipe. Differential settlement bends and other small offsets make it difficult to install liners larger than 90% of the ID of the original pipe ID. TV inspection and field evaluations will influence using the rule of thumb or using a larger or smaller fitting liner.

Example: The existing pipe is concrete pipe with an ID of 12". What is the 90% of the ID? $12" \times 90\% = 10.8$ inches.

The closest pipe size to 10.8 inches is 10.75" inch OD IPS HDPE pipe. See Appendix for pipe sizes and liner sizes.

2. Determine a liner wall thickness.

For gravity flow sewer applications, usually the ground water level determines the liner thickness. In the PPI PE Handbook (2nd ed.) , Chapter 11, "Pipeline Rehabilitation by Sliplining with PE Pipe", Table 1, "Allowable Height of Water " shows that a not-grouted PE 4xxx DR 26 pipe can handle 4 feet of water for 50 years with a safety factor of 2.

The table shows that by grouting, a greater depth can be obtained. In most situations, grout is not needed. Grout is used when the existing pipe is in very bad condition or there are large voids. Grouting is standard practice for culverts.

Example: A sewer line has a burial depth from four feet on one end to 20 feet on the other end. There is not ground water above the pipe on the shallow end. Where the pipe is buried 20 feet deep, the ground level is 4 feet above the pipe most of the year.

Since the ground water level is 4 feet, Table 2 shows that a DR 26 PE 4xxx pipe will handle the hydrostatic loading.

3. Determine the flow capacity

To determine the flow capacity, the installed slope of the old line is needed. For a comparison, we will assume that the slope of both lines is the same and is 0.001.

Example: Using Manning's equation in the PPI PE Handbook (2nd ed., p. 404) , the flow rate for 12" concrete pipe with a slope of .001 and "n" factor of 0.015 is determined to be 438 gpm.

The PE liner pipe is 10.75" OD DR 26 pipe. The slope is 0.001, and the "n" factor is .009. The flow rate after lining is 433 gpm.

4. Design necessary accesses.

Before any design is done, a field survey of the existing line is needed. The existing sewer line must be evaluated to determine the actual condition of the old sewer pipe and the above ground conditions related to traffic, other utilities and the impact of excavations.

The existing line must be inspected with closed circuit television to determine the condition of the old line (dropped joints, dirt, bellies, and repairs). The TV inspection can be used to locate services. Below are details needed:

a. Insertion pit:

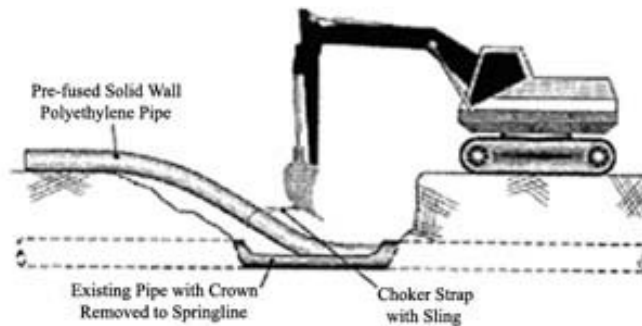

Figure 1 Push Technique for Solid Wall Polyethylene Pipe

- b. Sealing the annular space between the liner and the existing pipe at the manhole is important.

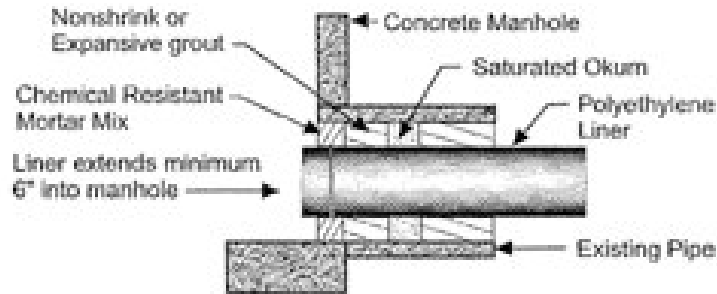
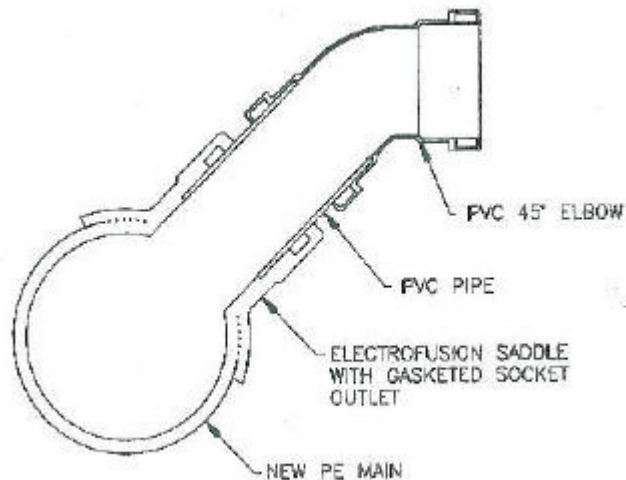
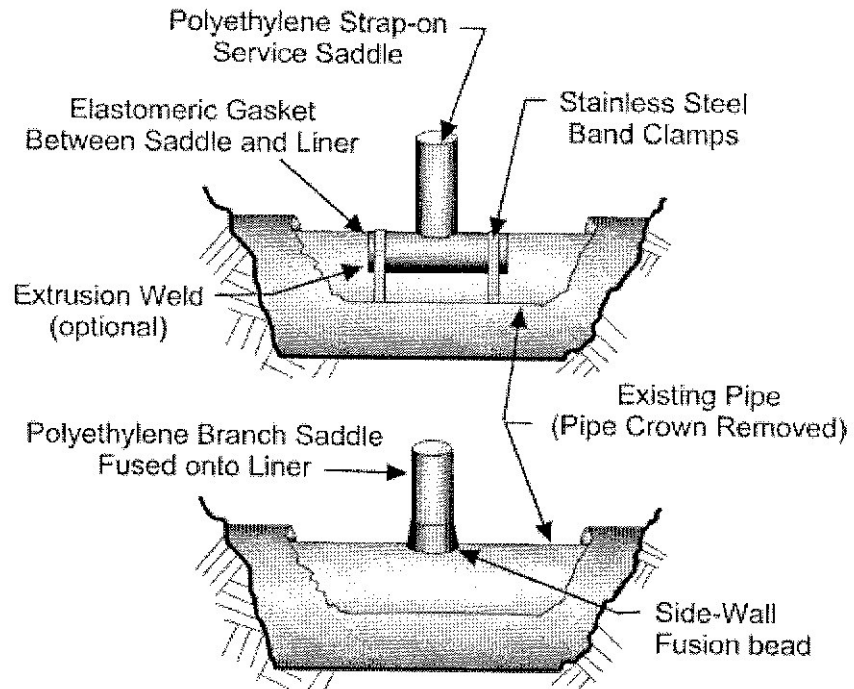

Figure 2 Typical Manhole Seal for Gravity Flow Applications

- c. Service connections must be connected to the liner. Electrofusion sewer saddles offer an excellent connection.



- d. Strap-on saddles are another alternative where existing conditions do not allow electrofusion.



e. Connections to new concrete manholes.

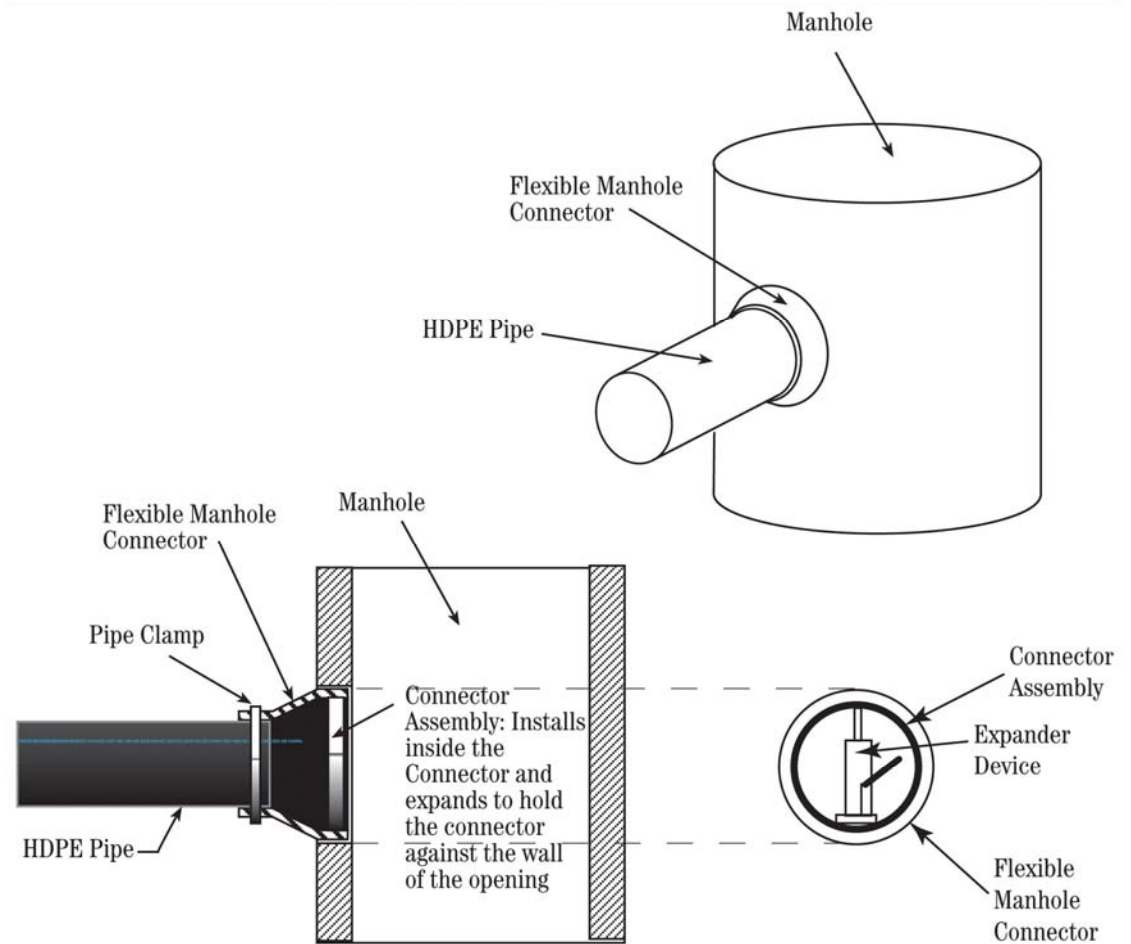
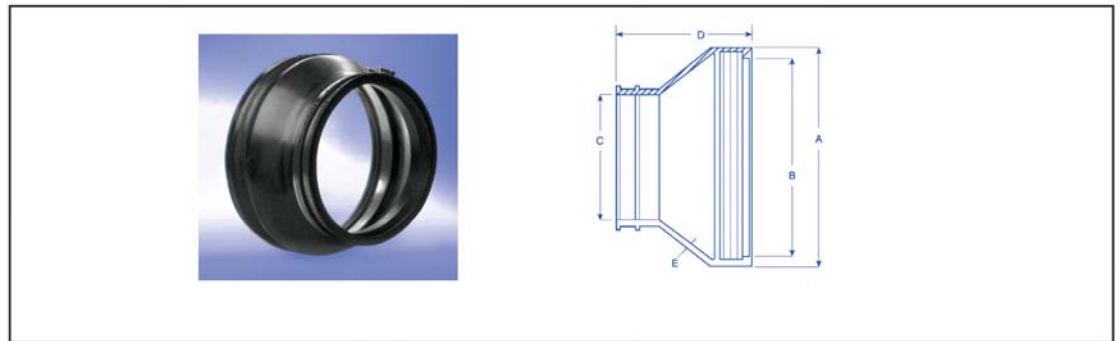

- f. Connections to cast in place manholes.

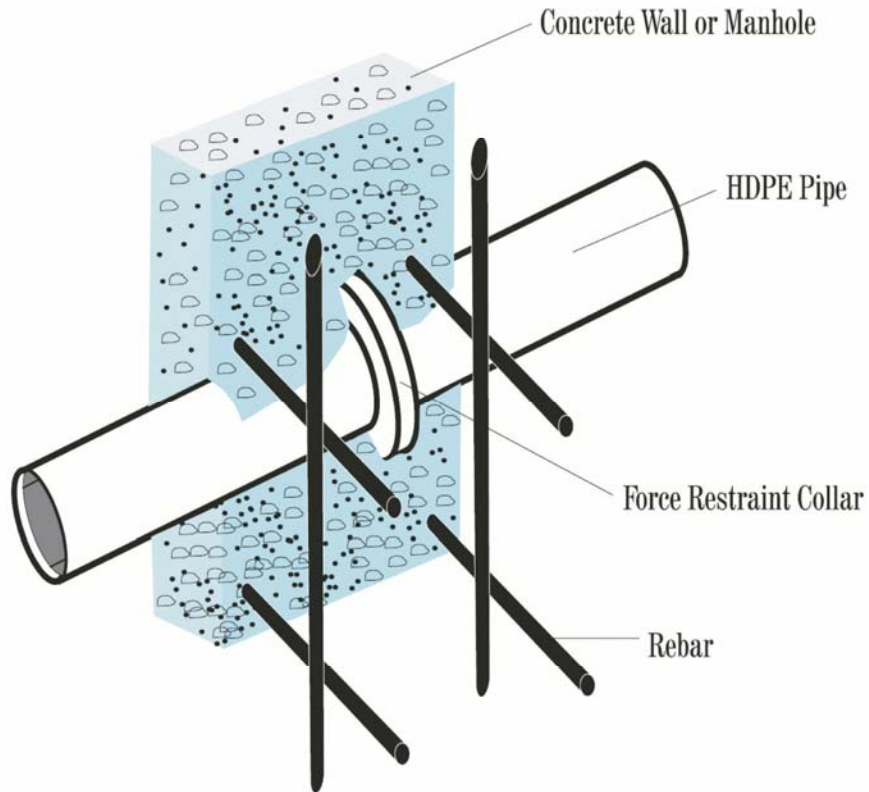

5. Develop the contract documents.

The contract documents usually contain technical specifications and pay items. The sample specifications show a specification created using the above example information:

Appendix

Table 1 provides typical existing sewer ID's and liners with an OD approximately 10% smaller than the existing sewer. Liner sizes are for solid wall HDPE pipe meeting OD requirements for ASTM F 714 and D 3035.

Table 1 – Sewer ID and Liner OD Dimensions

Existing Sewer ID	Liner OD
4"	3.5"
6"	4.5"
8"	6.626"
10"	8.625"
12"	10.75"
15"	12.75"
18"	16.00"
21"	18.00"
24"	20.00"
24"	22.00"
30"	28.00"
36"	32.00"
42"	36.00"
48"	42.00"
54"	48.00"
60"	54.00"
72"	63.00"

Table 2 shows the wall thickness required for various ground wall elevations.

Table 2 – PE 4 xxx DR Required for Groundwater above Liner Pipe*

SDR	Height of Water Above Pipe (50 years)	
	With no grout	With grout
32.5	2.0 feet	10.0 feet
26	4.0 feet	20.0 feet
21	7.9 feet	39.5 feet
17	15.4 feet	77 feet

*The figures in this table represent a safety factor of 2.0 with an assumed deflection of 3%. For PE 3xxx, refer to PPI PE Handbook, 2nd ed., chapter 11, Table 1.

MS-6/2009 Model Specification and Checklist for Polyethylene (PE) Pipe for the Sliplining of Sewers

MODEL SPECIFICATION

1.0 Intent

- 1.1 The intent of sliplining is to rehabilitate non-pressure gravity flow sewer lines by the insertion of a polyethylene liner pipe into the sewer line. When complete, the liner should extend from one manhole to the next manhole in a continuous, watertight length.

2.0 Reference Specifications and Publications

- 2.1 This document references American Society for Testing and Materials (ASTM) standard specifications, which are made a part hereof by such reference and shall be the latest edition and revision. It is incumbent upon the owner's representative to have a working familiarity with the following ASTM Standards:
 - ASTM D2321, *Practice for Underground Installation of Flexible Thermoplastic Pipe for Sewers and Other Gravity-Flow Applications*
 - ASTM D3035, *Specification for Polyethylene (PE) Plastic Pipe (DR-PR) Based on Controlled Outside Diameter*
 - ASTM D 3350, *Standard Specification for Polyethylene Plastics Pipe and Fittings Materials*
 - ASTM F 585 *Practice for Insertion of Flexible Polyethylene Pipe into Existing Sewers*
 - ASTM F714, *Specification for Polyethylene (PE) plastic pipe (SDR-PR) Based on Outside Diameter*
 - ASTM F 1417 *Standard Test Method for Installation Acceptance of Plastic Gravity Sewer Lines Using Low-Pressure Air*
 - PPI Handbook of Polyethylene Pipe

3.0 Sewer Liner Pipe and Fittings Requirements:

- 3.1 The polyethylene material dimensions and performance properties of solid wall polyethylene pipe shall be in accordance with ASTM D 3035 or ASTM F 714. The polyethylene material used to manufacture the pipe and fittings shall be high density polyethylene compounds which meet or exceed the cell classification PE 345464C in accordance with ASTM 3350-06*.
- 3.2 The polyethylene material dimensions and performance requirements for polyethylene fittings shall be in accordance with ASTM D 3261 for molded fittings or ASTM F 2206 for fabricated fittings or ASTM F 1055 for electrofusion fittings.

*When pressurized pipelines are sliplined, Polyethylene pipe made from resins with a minimum cell classification of PE 445474 C can be used.

4.0 Liner Pipe Dimensions and Saddles

- 4.1 Saddles fittings for connecting laterals to the liner shall be electrofusion or strap-on sewer saddles. Strap-on sewer saddles shall be used only where it is not possible to use electrofusion saddles. The saddles shall be equipped for joining with a casketed hub, or plain outlet for mechanical couplings or electrofusion couplings joining.

5.0 Submittal Requirements

Submittal information shall confirm products are manufactured in accordance with Sections 2 and 3 of this specification.

6.0 Rejection

Any PE piping materials may be rejected for failure to meet any of the requirements of the specification.

7.0 Installation Procedures

The following installation procedures shall be observed unless otherwise specified by the Owner's Representative:

- 7.1 Cleaning of Sewer Line: Prior to any sliplining of a line so designated, the Contractor shall clean debris out of the sewer line. The method of removal shall not damage the existing line.
- 7.2 Television Inspection: Video tapes, CD's or DVD's of the existing line shall be provided by the Owner's Representative for use by the contractor in planning the work. To confirm line condition, the contractor may inspect the line prior to starting the project. The contractor shall be responsible for locating services, obstructions and other problems prior to the sliplining and connecting the services.
- 7.3 Bypass Piping: The Contractor shall be responsible for bypass piping if required. The bypass shall be made by plugging an upstream manhole and pumping the sewage into a down stream manhole or adjacent system. The pump and bypass lines shall be adequate capacity and size to handle the flow. The contractor shall be responsible for any leakage during the operation of the bypass.
- 7.3.1 Butt fused HDPE pipe shall be used for the bypass.
 - 7.3.2 Under no circumstances will the dumping of raw sewage onto private property or into the city street be allowed.
 - 7.3.3 At the end of each working day, temporary tie-in shall be made between the relined section and the existing system.
 - 7.3.4 The bypass piping shall be operated in way that allows residents to have service.

- 7.4 Line Obstructions: It is the responsibility of the Contractor to clear the line of obstructions, solids, dropped joints, or collapsed pipe that would prevent insertion or damage the liner during insertion. Excavations to remove obstructions shall be approved by the Owner's Representative prior to the commencement of work.
- 7.5 Excavation: Insertion pits shall be only at locations shown on the drawings. If additional insertion pits are required, the Owner's Representative shall approve the insertion pits and their locations prior to starting this work. The insertion pit size shall be no larger than is necessary.
- 7.5.1 The pit shall be sloped as required by the manufacturer or supplier. The sides of the pit must be supported and conform to OSHA requirements.
 - 7.5.2 The pit shall be wide enough to install the liner without damage.
 - 7.5.3 Ground water pumping or well pointing shall be the responsibility of the Contractor.
 - 7.5.4 After insertion of the liner, the trench surrounding the liner pipe or surrounding the liner pipe and the top of the old pipe shall be filled with suitable properly compacted material. Sand stabilized with cement, crushed stone or flowable fill may be used. Backfill shall be compacted as noted on the plans.
- 7.6 Joining of HDPE Liner Pipe:
- 7.6.1 Solid wall HDPE pipe shall be joined in accordance with ASTM F 2620. All butt fusion welds shall be made by trained personnel. Butt fusion equipment shall be inspected prior to arrival at the job site. The equipment inspection form shall be available to the Owner's Representative.
 - 7.6.2 The Owner's Representative can require on site training of the operator. Equipment not in satisfactory condition will not be allowed to fuse the pipe.
 - 7.6.3 Solid wall HDPE pipe can be joined using stainless steel full encirclement clamps when insertion pipes are not located at the manhole.
- 7.7 Insertion of the Fused Liner: The polyethylene liner can be installed by pulling or pushing or a combination thereof.
- 7.7.1 During insertion, precautions shall be taken to protect the liner pipe from scratches and gouges. The liner shall be protected from ragged edges of the broken sewer pipe.

7.7.2 The liner pipe shall be allowed to relax and come to thermal equilibrium before sealing the annular space between the liner and the existing sewer pipe at the manhole. The liner must extend at least 8" into the manhole.

7.8 Manholes

7.8.1 Replacement: When a manhole is replaced, the replacement manhole shall be equipped with a boot connection. The boot will allow a secure connection to HDPE pipe. See detail d.

7.8.2 Sealing Polyethylene Pipe in existing Manhole: The annular space between the polyethylene liner and the existing sewer line shall be sealed where the liner enters or exits manholes. The pipe shall be allowed to relax and come to thermal equilibrium for a period of 24 hours before sealing. Seal the upstream manhole liner connection, connect services to the liner, and then seal the downstream manhole connection. Acceptable materials are urethane foam, oakum or low shrink grout.

7.8.2.1 Foam sealant shall not protrude into the manhole and shall be finished over with a quick-set, non-shrink cement grout.

7.9 Service Connections: After the liner has been secured in the upstream manhole, each existing service connection shall be reconnected to the new liner. Remove at least the top half of the host pipe to expose the liner for sewer service saddle connections.

7.9.1 Connections between the saddle outlet and to existing clay, concrete, or PVC laterals may be made using a bell connection on the electrofusion saddle if so equipped, or with mechanical neoprene connectors. Connections to HDPE laterals may be made using electrofusion couplings.

7.9.2 Prior to backfilling the service connection, the annular space between the original host sewer pipe and the liner upstream and downstream of the lateral connection shall be sealed. Acceptable materials for sealing are urethane foam and oakum or low shrink grout.

8.0 Backfill:

8.1 At all points where the liner pipe has been exposed (such as the insertion pit, at a service connection, or other points to remove obstructions), the polyethylene pipe and fittings shall be encased in cement-stabilized sand or other material as specified by the Owner's

Representative. The purpose of this encasement material is to support the liner and prevent deflection.

- 8.2 When encasement material is used, debris and soil shall be removed along each side of the existing pipe or the liner down to the spring line.
- 8.3 After the encasement materials is in place and accepted by the Owner's Representative, backfill shall be placed and compacted as required.

9.0 Final Acceptance:

- 9.1 After installation of the liner, the Contractor shall, at the option of the Owner's Representative, either TV inspect the sewer line or conduct a low pressure test on the liner.

10.0 Cleanup:

- 10.1 After the installation work has been completed and all testing found acceptable, the Contractor shall clean up the entire project area and return the ground cover to grade. All excess material and debris not incorporated into the permanent installation shall be disposed of by the Contractor. Sidewalks, driveways, and street surfaces shall be recovered.