

**Comparison of Traditional
HDPE Innerduct and “Fabric
Conduit” Alternative
TR-44 / 2006**



PLASTICS·PIPE·INSTITUTE[®]

1825 Connecticut Ave., NW Suite 680 Washington, DC 20009
www.plasticpipe.org

FOREWORD

This technical report was developed and published with the technical help and financial support of the members of the PPI (Plastics Pipe Institute, Inc.). The members have shown their interest in quality products by assisting independent standards-making and user organizations in the development of standards, and also by developing reports on an industry-wide basis to help engineers, code officials, specifying groups, and users.

The purpose of this technical report is to provide important information available to PPI on design factors and design coefficients recommended for thermoplastic pressure piping applications. These recommendations are based on discussions with several internationally recognized technical experts in the plastic pipe industry. More detailed information on its purpose and use is provided in the document itself.

This report has been prepared by PPI as a service of the industry. The information in this report is offered in good faith and believed to be accurate at the time of its preparation, but is offered without any warranty, expressed or implied, including WARRANTIES OF MERCHANTABILITY AND FITNESS FOR A PARTICULAR PURPOSE. Any reference to or testing of a particular proprietary product should not be construed as an endorsement by PPI, which do not endorse the proprietary products or processes of any manufacturer. The information in this report is offered for consideration by industry members in fulfilling their own compliance responsibilities. PPI assumes no responsibility for compliance with applicable laws and regulations.

PPI intends to revise this report from time to time, in response to comments and suggestions from users of the report. Please send suggestions of improvements to the address below. Information on other publications can be obtained by contacting PPI directly or visiting the web site.

The Plastics Pipe Institute

www.plasticpipe.org

March, 2006

Comparison of Traditional HDPE Innerduct and “Fabric Conduit” Alternative

Overview

The following is a comparison of traditional HDPE innerduct and the new “fabric conduit” alternative to innerduct. Both are products used to house and protect fiberoptic cables for the telecommunications industry. This report will focus on the strength and protection characteristics of each product, as well as ease of installation and use of each.

HDPE Innerduct

HDPE innerduct is an extruded plastic duct currently used extensively to house cables for the telecommunications industry. It can be installed in a variety of ways: it can be buried directly in the ground, run through the ground inside of a larger conduit (as innerduct), or overhead as an aerial duct.

Figure 1 - HDPE Duct

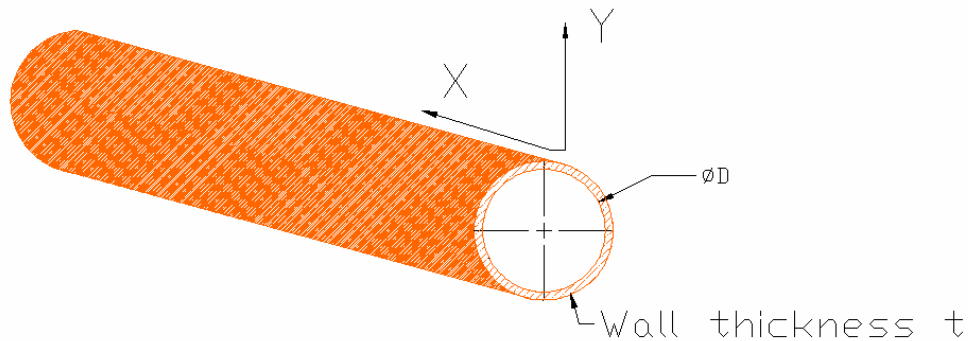

Fabric Conduit

“Fabric conduit” is a recent development in the industry. It consists of a continuous length of fabric which has been divided into three individual chambers. Each chamber is designed to house a single fiberoptic cable. The fabric conduit is intended to be pulled through a larger conduit and then have individual fiber cables pulled through it, increasing the amount of fiber cables that are able to be housed in a duct.

Figure 2 - Fabric Conduit

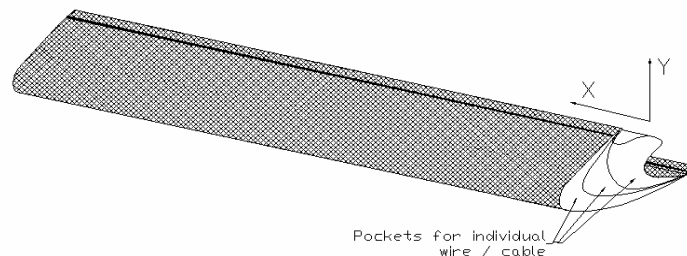

Comparison Criteria

The comparison between these two products focused on three critical characteristics: strength, ability to protect the cable, and ease of use and installation. Where possible, tests were performed to compare the physical properties of the two products.

Strength

All conduit and innerduct must exhibit strength in its lengthwise or X (Figures 1 and 2) direction to withstand the demands of either being direct buried or pulled through larger duct. In addition, it is critical that the conduit maintain adequate strength in its Y (Figures 1 and 2) direction as shown to stand up to the rigors of cable pulls and rodding if necessary.

X Direction Strength

To determine the tensile strength of the fabric conduit material, small strips of the fabric itself were removed and tested individually to determine the load at which they fail. From this data, and using the cross sectional area of the test strip, a tensile strength for the fabric can be estimated. The test results were as follows:

	Sample Width (in)	Thickness (in)	Load At Failure (lbs)	Tensile Strength (psi)
Sample 1	0.9	0.018	80	4938
Sample 2	0.9	0.018	65	4012
Sample 3	0.9	0.018	60	3704
Average:	0.9	0.018	68.3	4218

To translate this tensile strength information into the maximum force that can be exerted lengthwise on the fabric conduit, the cross-sectional area of the fabric conduit must be determined. Since the conduit consists of three pockets created by four individual strips of fabric, the cross sectional area is the sum of these four individual areas.

	Width (in)	Thickness (in)	Area (sq. inches)
Strip 1	4	0.018	0.072
Strip 2	4	0.018	0.072
Strip 3	3.5	0.018	0.063
Strip 4	5.5	0.018	0.099

Total area: 0.306 square inches

Now the maximum load that the fabric conduit can withstand in the lengthwise direction can be determined by taking the average tensile strength of 4218 psi and multiplying it by the cross sectional area of .306 square inches. The result being 1291 pounds.

In comparison, a HDPE innerduct with an outside diameter of 1.660" and an inside diameter of 1.464" has a cross sectional area of .480 square inches. Given a material tensile strength of 3350 psi, an innerduct of this size will fail at a load of 1608 pounds, a 25% larger load than the fabric conduit.

Y Direction Strength

While the HDPE innerduct proves to be slightly stronger than the fabric conduit in the lengthwise direction, it is in its Y direction as shown in the drawings that the HDPE exhibits superior strength. The fabric conduit's strength in this direction is limited by the strength of the stitching which holds the fabric pockets together. As this stitching fails, the pockets open up, rendering the fabric conduit unusable.

To test the stitching strength, several pieces of fabric conduit of differing lengths were cut and then were subjected to a force in the Y direction. The load at which the stitching failed was then recorded. The results are as follows:

	Width (in)	Load At Failure (lbs)	Tear Strength (lbs/inch)
Piece 1	1	56	56
Piece 2	2	195	97.5
Piece 3	3	302	100.7
Average			84.7

In comparison, the strength of HDPE innerduct in its Y direction can be determined by determining its cross sectional area in that direction and multiplying it by the material's tensile strength as seen below:

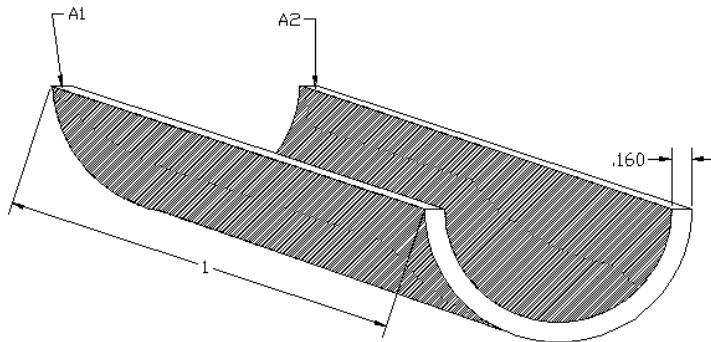

$$A1 = (.160) * 1 = .160$$

$$A2 = (.160) * 1 = .160$$

$$A1 + A2 = .320$$

square inches

$$(.320 \text{ sq. in.}) * (3350 \text{ psi tensile strength}) = 1072 \text{ lbs}$$

$$1072 \text{ lbs per one inch section}$$

HDPE innerduct proves to be greater than ten times stronger in this direction than the fabric conduit. This "weak link" in the fabric duct may result in the conduit's failure when subjected to loads in this direction. These may be loads that arise during cable pulling or during a rodding procedure to replace broken rope or tape.

Cable Protection

In addition to its greater strength characteristics, there are two additional ways that HDPE innerduct is superior to fabric duct in providing physical protection to the cable it houses. The first being that HDPE innerduct is an extruded pipe which provides a water-tight protective covering for expensive fiberoptic cables. When this innerduct is run through a larger four inch or six inch conduit, it doubles the amount of solid, water-tight protection for each fiber cable. While it is not essential to have this water-tight protection around each cable (as the cables themselves are water-tight) situations have developed where water within conduits have proven to be detrimental to the proper operation of the fiber cables. In areas where the buried conduit lies above the frost line or in areas that the conduit must travel above ground, water within the conduit freezes and presses against the fiber cable. This pressure in the cable can cause the signals within the fiber to degrade.

Fabric conduit on the other hand provides none of the above-mentioned protection. It consists merely of a woven plastic fabric. While the fabric's individual fibers themselves are water resistant as advertised, the fabric as a whole does nothing to keep moisture away from the cables themselves. Thus, when water enters a larger conduit either through a break in the conduit or

through condensation, the inner fabric conduit does nothing to protect the fiber cable from the hazards of ice.

In addition to providing added protection from moisture, HDPE innerduct also isolates cables from others within the larger conduit. In most cases, since a single cable is pulled through a single innerduct, the innerduct provides protection from other cables being pulled either in or out of the larger conduit. In addition, it also provides greater accessibility to each individual cable in the event that a cable needs to be replaced.

Ease of Installation

HDPE is used by communications companies to provide a CLEAN, low friction path. It is well known that most conduit systems have infiltration of water and sediment over time. Sediment cannot enter HDPE once installed with end caps installed and this is important when spare conduits are installed for future use.

The idea of a fabric conduit is based on the concept of being able to pull a greater number of fiber cables through existing sizes of conduit. For example, the theory is to be able to pull three fabric conduits through a four inch diameter rigid conduit and then in turn pull three individual fiber cables through each fabric conduit, each cable being pulled individually. Manufacturers stress the ease of being able to pull the fabric conduits through the larger duct due to the fact that unlike HDPE innerduct "spiraling" of the conduits does not occur.

Spiraling is a term used to describe what happens to innerduct after it has been pulled through a larger conduit. Since the innerduct has been stored on a reel for a length of time and is then straightened out under tension as it is pulled, it tends to want to recoil itself once the tension is removed. This "recoiling" is what causes the innerduct to spiral within the larger conduit.

What is overlooked with the fabric conduit is that spiraling not only occurs with innerduct, but will also occur with any type of fiber or copper cable that has been stored on a reel. So while the fabric conduit itself will not spiral within the larger conduit, each individual cable being pulled through the fabric conduit will. Due to the fact that the fabric conduit is so flexible, it will spiral along with each cable being pulled through, making installation more difficult. Not only will this spiraling make installation difficult, it will also make it almost impossible to replace any individual cable within this fabric conduit if the need may arise in the future.

Summary

In looking at the data and analysis listed in this report, it is clear that HDPE proves itself to be a reliable product in providing strength and protection to the cables housed within. In addition, it also has the ability to facilitate smooth and efficient cable pulls as well as cable extractions. On the other hand, while stressing increased cable density, fabric conduits show themselves to be a product that remains vulnerable to the installation problems associated with cable spiraling without offering additional protection the HDPE conduit provides. The fabric conduit may provide initial low friction installation, but future use of the spare channels is likely to be impaired due to build up of sediment within the conduit itself. Future removal of cables from a fabric conduit is likely to be difficult if not impossible due to twisting and possible sediment build up within the fabric conduit.