

Municipal Advisory Board

Established May 1, 2008, at the University of Texas, Arlington



MAB Model Specifications for PE4710 Buried Potable Water Service, Distribution, and Transmission Pipes and Fittings (MAB-3 2026)

[Refer to MAB website to ensure the use of the most current version]

www.plasticpipe.org/MABpubs

4th ed. approved at the 36th MAB meeting. Hosted by City Utilities, Fort Wayne, IN, June 2026
3rd ed. approved at the 31st MAB meeting. Hosted by the Miami-Dade Water & Sewer Dpt., FL, 2023
2nd ed. approved at the 24th MAB meeting. Hosted by the Detroit Water and Sewer Dpt., MI, 2019
1st ed. approved at the 17th MAB meeting. Hosted by Milwaukee Metro. Sewerage District, WI 2017
© **Plastics Pipe Institute, 2017, 2019, 2023, 2026**

FOREWORD. This model specification was developed by the Municipal Advisory Board (MAB) and published with the help of the Plastics Pipe Institute, Inc. (PPI).

This model specification is intended as a guide for engineers, users, contractors, code officials, and other interested parties for use in the design, construction, and installation of high-density polyethylene (HDPE) pressure water piping systems. The local utility or engineer may need to modify this model specification to adapt the document to local conditions, operations, and practices.

This model specification has been prepared by MAB members and associates as a service to the water industry. The information in this document is offered in good faith and believed to be accurate at the time of its preparation but is offered "as is" without express or implied warranties, including WARRANTIES OF MERCHANTABILITY AND FITNESS FOR A PARTICULAR PURPOSE. Any reference to a specific manufacturer's product is merely illustrative and not intended as an endorsement of that product. Reference to or testing of a proprietary product should not be construed as an endorsement by the MAB or PPI, which do not endorse the proprietary products or processes of any manufacturer. Users are advised to consult the manufacturer for more detailed information about the specific manufacturer's products. The information in this document is offered for consideration by industry members in fulfilling their own compliance responsibilities. MAB and the PPI assume no responsibility for compliance with applicable laws and regulations.

The MAB serves as an independent, non-commercial adviser to the Municipal & Industrial (M & I) Division of the PPI. Once adopted, MAB will consider revising this specification from time to time, in response to comments and suggestions from users of the model specification. Please send suggestions of improvements to Camille George Rubeiz, PE, F. ASCE, at crubeiz@plasticpipe.org

ACKNOWLEDGEMENTS

The Municipal Advisory Board would like to acknowledge the excellent contributions of the MAB-3 Model Specification Task Group for developing and leading this project to provide the water utilities and communities with the best HDPE solutions.

1. Casey Haynes, PE City Utilities, Springfield, MO (past); H2E, MO
2. Amster Howard Bureau of Reclamation (past), Civil Engineering Consultant, CO
3. Kevin Miller Miller Pipeline, IN
4. Dr. Mo Najafi, PE CUIRE, Univ. of Texas, Arlington
5. Michael Saadeh City of Ft. Wayne, IN
6. Andrew Schipper, PE City of Ft. Wayne, IN
7. Greg Scoby, PE City of Palo Alto, CA (past)
8. Austyn Smedberg, PE City of Ft. Wayne, IN
9. Cheryl Wilson, PE City of Tulsa, OK

MUNICIPAL ADVISORY BOARD MEMBERS

UTILITIES

1. **Marisa Boyce, PE**, EBMUD, CA
2. **Angelo Dupont**, Arlington Water Utilities, TX
3. **Dale Harmon**, Boothbay Region Water Dist., ME
4. **Jeff Kyle, PE**, City of Austin, TX
5. **Evan Martin, PE**, MUD-Omaha, NE
6. **Jacob Nakano**, City Utilities, MO
7. **Lance Rothe, PE**, SAWS, TX
8. **Kaitlyn Saucedo**, City of Round Rock, TX
9. **Howard Smith, PE**, City of Duluth, MN
10. **Cheryl Wilson, PE**, City of Tulsa, OK
11. **Matthew Wirtz, PE**, City of Ft Wayne, IN

UNIVERSITIES

1. **Prof. Tom Iseley, PE**, Purdue University, IN
2. **Prof. Mo Najafi, PE**, CUIRE, Univ. of Texas, Arlington
3. **Prof. Dan Koo, PE**, Univ. of North Florida

FORMER MEMBERS:

Jessie Allen, PE, Arlington Water Utilities, TX
Alan Ambler, PE, Casselberry, FL (past), AM Trenchless, FL
Prof. Alan Atalah, PE, Bowling Green State Univ, OH
Prof. Sam Ariaratnam, PE, Arizona State University
Joe Castronovo, PE, AECOM (ret.), ASCE UESI, GA
Robert Diamond, PE, City of Palo Alto, CA
Mariana Evora, PE, City of Miami Beach, FL
David Freireich, PE, City of Round Rock, TX
Todd Grafenauer, Murphy Pipeline, WI
Mike Heitmann, Garney Construction, MO
Nelson P. Jacome, PE Miami-Dade Water & Sewer Dept., FL
Todd Jorgenson, City of Austin, MN
Robert Justus, City of Palo Alto, CA
Holly Link, Colorado Springs Utilities, CO
Gordon Mahan, San Antonio Water System, TX
Milton Keys, Indy Water/Veolia, IN

CONTRACTORS

1. **Casey Haynes, PE**, City Utilities, MO (past); H2E, MO
2. **Richard Crow, PE**, Murphy Pipelines, WI
3. **Kevin Miller**, Miller Pipeline Co., IN

CONSULTANTS

1. **Luis Aguiar**, Miami-Dade WASD (past), Hazen & Sawyer, FL
2. **John Fishburne, PE**, Charlotte Water (past), Freese & Nichols, NC
3. **Amster Howard**, Reclamation (past), Civil Eng'g. Cons., CO
4. **Steven Kramer, PE**, COWI North America, NJ, UESI
5. **Ernest Lever**, GTI Energy, IL
6. **Greg Scoby, PE**, Palo Alto, CA (past)

PPI, Camille Rubeiz, PE, M&I Division, TX

Matthew Klein, Veolia/ Citizens Energy, IN
Prof. Mark Knight, PEng, CATT/Univ. of Waterloo, ON
Ed Lambing, PE, San Jose Water Co., CA
Jonathan Leung, PE, LA Dept. of Water & Power, CA
George McGuire, Ditch Witch, OK
Dr. Ken Oliphant, PEng, JANA, ON
Rafael Ortega, PE, LAN, TX
Collins Orton, TT Technologies, CA
Fred Ostler, PE, City of Boise, ID
Chad Owens, PE, City Utilities, MO
Eric Shaffer, PE, City of Duluth, MN
Dr. Larry Slavin, OPCS, NJ
Dan Smolik, Garney Construction, FL
Dave Stewart, Lago Vista (past), S. HDPE Consulting, TX
Serge Terentief, PE, EBMUD, CA

MAB-3: MAB Model Specifications for PE4710

Buried Potable Water Service, Distribution and Transmission Pipes and Fittings

PART 1 – GENERAL

1.1 The scope of this model specification is for high-density polyethylene (HDPE) water piping systems that conform to AWWA standards. This model specification can be adopted in full or modified by the specifier to suit the project. This model specification provides minimum requirements for PE 4710 pipes and fittings to be used in the design and construction of potable water piping systems.

1.2 DESCRIPTION

- A. Scope: MAB-3 provides a model specification for HDPE pipes and fittings for use by water utilities and consultants as indicated on the drawings, and as shown herein.
 - i. Furnish, install, and test HDPE piping system as indicated and specified herein and as shown in the Drawings.
 - ii. The primary installation method addressed is direct burial by open cut; see MAB-5 and MAB-7 for pipe bursting and Horizontal Directional Drilling (HDD). The means and methods, including the testing for acceptance, shall conform to all applicable standards as noted herein with the intention of providing a leak-free self-restrained piping system for the owner.

1.3 REFERENCES

- A. To the extent referenced in this specification, the standards and documents listed in Appendix A are included and are made part of this specification.
- B. In the event of a conflict, the requirements of the project specification shall prevail.
- C. Unless otherwise specified, references to documents shall mean the latest published edition of the referenced document in effect at the bid date of the project.

1.4 SYSTEM DESIGN PARAMETERS

- A. Per AWWA C901, C906 and M55, the Allowable Total Pressure during Recurring Surge conditions (cycles) equals 1.5 times the pipe’s Pressure Class (PC). Allowable Total Pressure during Occasional Surge conditions (cycles) equals 2.0 times the pipe’s PC. Refer to Table 1 for details.
- B. Flow Capacity: Per AWWA C906: “Matching the ID of other pipe materials to the ID of HDPE for flow and PC will yield incorrect results. Use PPIPACE.com to evaluate flow capacity and PC of HDPE [relative] to other materials.” Refer to Table 2 for AWWA recommended design values for flow velocities and number surge of cycles. Refer to Table 3 for an example evaluating flow capacity, PC and required fatigue life of HDPE versus other materials.
- C. Water Hammer/ Fatigue Life: In the absence of a calibrated hydraulic model, refer to Table 2 for minimum and average flow velocities and minimum number of cycles.
- D. Seismic: Refer to AWWA M55 (Apdx B), [MAB-9](#), MAB-10, and HDPEapp.com

Table 1: PE4710 Preferred Pressure Classes per AWWA C906 and C901 (up to 80°F)

Pipe Dimension Ratio (DR)	Pressure Class / Rating (psi)	Allowable Total Pressure during Recurring Surge (psi)	Allowable Total Pressure during Occasional Surge (psi)	AWWA C906	AWWA C901	Allowable Hydrotest (Field) Pressure (psi)
DR 17	125	188	250	Yes	NA	188
DR 13.5	160	240	320	Yes	NA	240
DR 11	200	300	400	Yes	NA	300
DR 9	250	375	500	Yes	Yes	375

Table 2: AWWA M55 Recommended Design Values for Flow Velocity and Fatigue

	Recurring Flow Velocity	Occasional Flow Velocity	Cycles / day	Design Fatigue Life
Minimum	4 fps	8 fps	55	100 years
Average	6.7 fps	11.6 fps		

Table 3: Example- Comparison of required AWWA Pressure Class (PC), Flow Capacity, and Design Fatigue Life for HDPE, PVC and DI

8" DIPS/CIOD	HDPE** (PE4710)	PVC	Ductile Iron**
AVG. Operating Conditions	70 psi at 57°F		
Required Flow	695 gpm (Recurring Surge) / 1,390 gpm (Occasional Surge)		
PC *	PC125 (DR17)	PC235 (DR18)	PC350
AVG. Inside ID *	7.92"	7.98"	8.43"
Head Loss (1,000 ft)	3.3 / 11.8 psi	3.1 / 11.3 psi	2.7 / 9.9 psi
Resultant Flow Velocities	4.52 fps / 9.05 fps	4.45 fps / 8.91 fps	4 fps / 8 fps
Design Fatigue Life (55 cycles /day)	100 years	39 years	Not Available

*Per AWWA C906 (2021, p. 29): "Matching the ID of other pipe materials to the ID of HDPE for flow and PC will yield incorrect results. Use PPIPACE.com to evaluate flow capacity and PC of HDPE to other pipe materials."

** Refer to Appendix I for features and benefits

1.5 SUBMITTALS: Quality Assurance / Control Submittals

- A. Affirmation that product shipped meets or exceeds the requirements of the standards set forth in this specification. This shall be in the form of a document from the product's manufacturer attesting to the manufacturing process meeting the standards including associated testing reports confirming compliance.
- B. Owner reserves the right, at its own cost, to conduct in-plant audit and observe extruding/molding facilities.

1.6 DELIVERY – STORAGE – HANDLING

- A. Handle and store the pipe in accordance with the PPI *Handbook of Polyethylene Pipe, Chapter 2* using approved strapping and equipment rated for the loads encountered. Do not use chains, wire rope, forklifts or other methods or equipment that may gouge or damage the pipe or endanger people or property.
- B. Ship with recyclable endcaps or other suitable sealing devices to prevent contamination during shipping.
- C. Refer to MAB-6 (titled Guidelines for HDPE Pipeline Inspection) for documenting condition of pipe (and all other HDPE related materials) upon delivery. If any gouges (10% or greater of wall thickness), scrapes, or other damage/manufacturing defects are noted, these materials shall be rejected. Other possible reasons for rejection include pipes that do not meet the project specifications (e.g., incorrect markings, blue striping, and/or DR), wrong sizes/sizing standards (DIPS, IPS, CTS), missing end caps, and/or other specified items.

PART 2 – HDPE PRODUCTS FOR 4 INCH AND LARGER PIPE PER AWWA C906

2.1 – PIPE

- A. HDPE pipe from 4” to 65” diameters shall be PE4710 conforming to the latest edition of [ANSI/AWWA C906](#) and ANSI/NSF Standard 61. For potable water applications, PE4710 compound shall conform to ASTM D3350 minimum Cell classification *PE445574C-CC3*.
 - i. HDPE pipes should be extruded by a [PPI member](#) listed in [PPI TR-4](#) and shall meet the requirements of AWWA C906. Sample list of sizes is shown in Appendix B.1.
 - ii. Dimensions and tolerances for HDPE pipes and fittings shall meet the requirements of AWWA C906.
- B. HDPE pipe shall be rated for use at a pressure class of _____ *[User specified]* psi. *[The specifier chooses the pressure class from Table 1].* The outside diameter of the pipe shall be based upon either IPS or DIPS sizing systems. *[User to specify the appropriate sizing system on the plans.]*
- C. Pipe marking in accordance with Section 2.3.

2.2 FITTINGS

- A. Butt Fusion Fittings – HDPE Fittings shall be made of PE4710 and with a minimum Cell Classification as shown in Section 2.1.A. All HDPE fittings shall meet the requirements of AWWA C906 and shall have a pressure rating equal to the pressure rating of the pipe to which the fitting is joined.
- B. Molded fittings (including both butt end and sidewall/branch fittings) shall be manufactured, tested, and marked per ASTM D3261. When the required molded fitting is not available in the project specified DR, a thicker wall molded fitting can be used to maintain the PC, and the spigot ends of the thicker wall molded fitting should be modified by the fitting manufacturer or approved representative to match the DR and the nominal OD of the pipe being installed.
- C. Fabricated fittings shall be manufactured, tested, and marked per AWWA C906 and ASTM F2206. Per AWWA C906, the “PC of a fitting shall be the same as or greater than the pipe to which the fittings will be joined...” Fitting design should include an allowance for surge that is at least equal to the surge allowance for the pipe. When a thicker wall is used to manufacture the fitting to maintain the PC, ends of fitting shall be machined by the fitting manufacturer (or approved representative) to match the DR and the nominal OD of the pipe being installed. Fabricated fittings made with mitered fusion joints shall also be constructed with an appropriate amount of reinforcement but with a minimum of 1 SDR reinforcement (GSR 0.82). Additional reinforcement may be necessary for anticipated dynamic or structural loads. Reference the [2016](#) and [2026](#) GTI/PPI reports on elbows and tees for reinforcement assessment.
- D. Electrofusion Fittings (EF) - Fittings shall be made of HDPE material with a minimum material designation code of PE4710 and with a minimum Cell Classification as noted in Section 2.1A. EF fittings shall have a manufacturing standard of ASTM F1055 and shall have a pressure rating equal to the pipe unless otherwise specified on the plans. Markings shall be according to ASTM F1055, including couplings and sidewall / branch fittings. Tapping tees and all components shall be in compliance with Annex "G" or NSF/ANSI 372 as conforming with the lead content requirements for “lead free” plumbing as defined by local state/provincial laws and the U.S. Safe Drinking Water Act.

All electrofusion (EF) fittings must remain in original factory packaging until installation. Any EF fittings not in original packaging shall be rejected.

- E. Mechanical Joint adapters (MJ adapters) – MJ adapters shall have a material designation code of PE4710 with a minimum Cell Classification as noted in Section 2.1.A. MJ adapters shall be made in accordance with ASTM D3261. MJ adapters shall have a pressure rating equal to the pipe to which it is joined unless otherwise specified on the plans. Markings for MJ adapters shall be per ASTM D3261. MJ Adapter accessories, whether supplied in kits or individual parts, shall include the following:
- AWWA C110 metal glands marked (AWWA C110)
 - Bolts & Nuts shall be High Strength Low Alloy (HSLA) with fluoropolymer finish or Stainless Steel (SS) as specified by the owner.
 - MJ Gaskets shall be as specified by the owner.
 - MJ adapters are the preferred connection method over other mechanical fittings. MJ adapters internal diameters should be checked for butterfly valve clearance, when used, to allow full disc rotation and movement prior to installation in the trench.
- F. Flanges – Flanges shall have a material designation code of PE4710 with a minimum Cell Classification as noted in Section 2.1.A. Flanges shall be made in accordance with ASTM F2880. Flanges shall have a pressure rating equal to the pipe to which it is joined unless otherwise specified on the plans. Markings for molded or machined flange adapters shall be per ASTM D3261.
- G. Mechanical Fittings for pipes - Three primary mechanical fittings or connections that can be used are Stab or insert type; compression type; and clamp ring. Per MAB-4, “Internal stiffeners should be used for all mechanical couplings”. Mechanical fittings shall be designed to restrain and to prevent pull-out or rotation. Refer to Appendix D titled Degradation of Gaskets with Chlorine and Chloramine.
- H. Service connections shall be either electrofusion branch saddles/tapping tees, sidewall fusion branch saddles / tapping tees, butt fusion tees or mechanical saddles. The Owner shall designate outlet diameter and type for each service specified. Various outlet configuration types are available including plain end HDPE or threaded metal in numerous thread types as following:
- i. For electrofusion saddles with metallic threaded outlets, the size of the outlet shall be as shown on the plans including metallic material and thread type. Electrofusion saddles shall be made from materials required in Section 3.1.A.
 - ii. For sidewall fusion saddles, the size of the outlet shall be as indicated on the plans. The saddle can be made in accordance with ASTM D3261 or ASTM F2206.
 - iii. Sidewall tapping tees shall be made to ASTM D3261 or D2683 and MSS SP-60 or if electrofusion shall be made to ASTM F1055. Tapping tees shall comply with Annex "G" or NSF/ANSI 372 as conforming with the lead content requirements for “lead free” plumbing as defined by local state/provincial laws and the U.S. Safe Drinking Water Act.
 - iv. Refer to Appendix H for details.

2.3 PIPE AND FITTING IDENTIFICATION

- A. The pipe shall be marked in accordance with the standards to which it is manufactured. *[or alternative as below]*

Markings shall include the following items: Nominal size (such as 12”), outside diameter base (such as DIPS), dimension ratio (such as DR 17), manufacturer’s name or trademark, standard materials designation code (PE4710), PE compound oxidative resistance for potable water (CC3), pressure class (such as PC 125), standard’s designation (AWWA C906), manufacturer’s production code, date of manufacture, mark of the certifying agency for potable water (such as NSF).

Markings shall be applied so that the intervals between markings are no greater than 5 ft.

- B. Color identification by the use of stripes on pipe or solid wall blue to identify pipe service. For potable water pipe, three blue stripes (min.) are required (on black material) and are spaced equally around the pipe OD. Fittings are typically not striped.

PART 3 – HDPE PRODUCTS FOR 3 INCH AND SMALLER PIPE PER AWWA C901

3.1 PIPE

- A. HDPE pipe with ¾” to 3” diameter shall be PE 4710 conforming to the latest edition of ANSI/AWWA C901 and ANSI/NSF Standard 61. For potable water applications, PE4710 compound shall conform to ASTM D3350 minimum Cell classification PE445574C-CC3.
- B. HDPE pipes should be extruded by a [PPI member](#) listed in [PPI TR-4](#) and shall meet the requirements of AWWA C901. Dimensions and tolerances for pipe and fittings shall meet the requirements of AWWA C901. Sample list of sizes is shown in Appendix B.2.
- C. Per AWWA C901, PE4710 pipes shall have a pressure class of 250 psi. The outside diameter of the pipe shall be based upon either the IPS or CTS sizing systems. *[User to specify the appropriate sizing system on the plans.]*

3.2 FITTINGS

- A. Butt Fusion Fittings: HDPE Fittings shall be made of PE4710 and with a minimum Cell Classification as shown in Section 3.1.A. All HDPE fittings shall meet the requirements of AWWA C901. Molded fittings shall be manufactured, tested and marked per ASTM D3261 and AWWA C901.
- B. Socket fittings shall meet ASTM D2683.
- C. Electrofusion and sidewall fusion saddles are also used for service connections. The pipe and saddle must be properly prepared and attached per MAB-1 electrofusion procedures or ASTM F2620 as applicable.
- D. Electrofusion Fittings (couplings): Refer to Section 2.2 B
- E. Flanges: Flanges shall be PE4710, with a minimum Cell Classification as noted in Section 3.1.A. Flanged adapters can be made to ASTM D3261 or if machined, must meet the requirements of ASTM F2206. Flanges shall have a pressure rating equal to the pipe unless otherwise specified on the plans. Markings for molded or machined flange adapters shall be per ASTM D3261.
- F. Mechanical Fittings for service pipes: Three primary mechanical fittings or connections can be used, which are: Stab or insert type; compression type; and clamp ring. Per MAB-4, “Internal stiffeners should be used for all mechanical couplings”.

- I. Transition Fittings: Transition Fittings are available in numerous configurations, including male and female threads, flared end, and others. All fittings shall be pull-out resistant, designated as Category 1. Owner shall specify outlet configuration of fittings.

3.3 PIPE AND FITTING IDENTIFICATION

- A. The pipe shall be marked in accordance with the standards to which it is manufactured. [*or alternative as above*]

Markings shall include nominal size, outside diameter base (e.g. CTS), dimension ratio (DR 9), manufacturer's name or trademark, standard materials designation code (PE4710), PE compound oxidative resistance for potable water (CC3), pressure class (PC 250), standard's designation (AWWA C901), manufacturer's production code, date of manufacture, mark of the certifying agency for potable water (such as NSF).

- B. Color identification: Refer to section 2.3 B.

PART 4 – JOINING

4.1 TRAINING AND INSPECTION

- A. Refer to ASTM F3190, ASTM F3565, MAB-01, MAB-02 and MAB-06 for recommended training and inspection for butt-fusion, sidewall-fusion, socket-fusion and electrofusion joints. All equipment shall be inspected and personnel training requirements completed and verified prior to commencing construction. Each fusion technician shall be qualified to specifically make the required fusion joint; qualification shall be demonstrated by evidence of training within one year on the equipment and pipe size(s) to be utilized for this project. Training shall include successful destructive testing of prepared joints.
- B. The installation of the pipe shall be observed by full-time, trained inspectors. Inspection check lists for Trench Excavations, Trench Walls, Foundation, Bedding, Laying, Embedment, Backfill, and Flowable Fill are available in the book *Pipeline Installation 2.0*.

4.2 JOINING METHODS

The pipe and fittings shall be joined by heat fusion or electrofusion couplings, mechanical joint (MJ) adapters, or by flange connections in accordance with manufacturer's recommendations and as required in this document. Unless otherwise shown on Drawings and except for connections to dissimilar material piping, all joints shall be fused.

- A. Butt Fusion: Prior to fusion the pipe shall be clean, and the ends shall be cut square. ASTM F2620 butt-fusion is for joining pipes and fittings that have the same nominal outside diameter and same wall thickness; for unlike walls, refer to ASTM F2620, section X1.4 titled Butt Fusion with Unlike Wall Thicknesses, or use EF without need to modify walls. For fusing in cold weather (any temperature below 32°F), and/or inclement weather (snow, rain, wind conditions), refer to MAB-8. Field site butt-fusion system operators shall be trained in the use of functional butt-fusion equipment capable of recording fusion quality that secures and precisely aligns the pipe ends for the fusion process. Operators shall be trained by the pipe supplier or manufacturer of the fusing machine and be experienced in the operation of the equipment including fusion data capture. Fusion quality shall be recorded, and the recorded information must be provided to the Owner. The Owner will review documents within 7 days and identify any fusion records that might indicate the need to replace an

existing fused connection. The recorded fusion information must meet the standard requirements of ASTM F3124. All fusions failing to meet these requirements shall be removed and the joints shall be fused again. Refer to ASTM F2620, ASTM F3124, ASTM F3183 and ASTM F3190. At the start of each workday the butt fusion technician shall prepare a fusion joint matching the diameter of each pipe being installed for destructive testing to verify that the equipment and fusion process are acceptable.

- B. Saddle fusion (Sidewall): Saddle fusion shall be done in accordance with ASTM F2620. Saddle fusion joints shall be made by qualified fusion technicians. Qualification of the fusion technician shall be demonstrated by evidence of fusion training within the past year on the equipment to be utilized on this project. [*Saddle fusion is used to fuse branch saddles, tapping tees, and other HDPE constructs onto the wall of the main pipe*] (ASTM F905).
- C. Socket Fusion: Molded socket fusion fittings are only to be used for joining of HDPE pipe from ¾ inch to 2-inch sizes. Fusion shall be done in accordance with ASTM F2620. Socket fusion is the process of fusing the pipe to fitting by the use of male and female ends that are heated simultaneously and pressed together so the outside wall of the male end is fused to the inside wall of the female end. Qualification of the fusion technician shall be demonstrated by evidence of socket fusion training within the past year on the equipment to be utilized on this project.
- D. Electrofusion: Electrofusion joining shall be done in accordance with the manufacturers' recommended procedure and ASTM F1055, ASTM F3565, MAB-01 and MAB-02. Qualification of the fusion technician shall be demonstrated by evidence of electrofusion training within the past year on the equipment and pipe sizes to be utilized for this project. Installers shall follow the guidance shown in the previous documents to fabricate EF assemblies. The installer must remove oxidation from the pipe OD and maintain a clean surface on both pipe and fitting to ensure acceptable joint quality. The fusion assembly must remain in a clamped position until the required cooling time has elapsed.
- E. Mechanical:
 - i. Mechanical connection of HDPE to auxiliary equipment such as valves, pumps, and fittings shall use flanges or mechanical joint adapters and other devices in conformance with AWWA Manual of Practice M55, Chapter 6. Mechanical connections shall be manufactured for use with HDPE. Per MAB-4, stiffeners shall be required for use with all mechanical connections.
 - ii. Mechanical connections on pipe 3" and smaller are available to connect HDPE pipe to other HDPE pipe, fittings, or to a transition to another piping material. The use of stab-fit style couplings is allowed, along with the use of metallic couplings of brass and other materials and shall be fully restrained. All mechanical and compression fittings shall be recommended by the manufacturer for use with HDPE and potable water.
 - iii. Mechanical Couplings shall be recommended by the manufacturer for use on HDPE at the required pressure class, incorporate an internal stiffener and be fully self-restrained.
 - iv. Mechanical branch or service fittings that wrap around the pipe and act as saddles are made by several manufacturers specifically for HDPE water pipe. All such saddles shall be recommended by the manufacturer as being designed and tested for use with HDPE water pipe at the required pressure class (Section 1.4).

PART 5- INSTALLATION

A. Open Trench Installation:

- i. Install the pipe in accordance with the engineering drawings and AWWA M55. Any deviation shall be approved by the Engineer.
- ii. Take care when placing, moving, or removing the trench boxes, sheeting or shoring, or bracing to prevent disturbance of the pipe and the embedment soils. Any voids or disturbances shall be refilled and re-compacted.
- iii. Per AWWA M55, "PE pressure piping must be assembled with fully restrained joints or with partially restrained joints AND external joint restraints. Pressure piping systems that are joined by heat fusion, electrofusion, flanges, and MJ adapters are fully [self-] restrained and do not require external joint restraints or thrust block joint anchors." Reinforced concrete anchor-blocks should be installed when connecting HDPE to unrestrained pipes. Refer to [PPI PE Handbook \(Chp. 7\)](#), Appendix G, AWWA M55, HDPEapp.com, and Anchor Blocks for HDPE Water Pipes (Stewart).

B. Water Mains and Accessories. HDPE connections to other pipe materials or valves and fire hydrants shall be made by mechanical joints, flanges or transition fittings. Valves and fire hydrants with HDPE stubs are available and recommended to avoid mechanical joints. All connections to jointed gasketed pipe materials, valves, or fire hydrants must be restrained and supported independently.

- i. **Restrained Mechanical Joints:** Restrained mechanical joints shall be made using mechanical joint adapters.
- ii. **Flange:** Flange connections shall be as described in Section 4.3.B.

C. Appurtenances: All appurtenances (tees, elbows, services, valves, air relief valves, fire hydrants, etc.), must be independently supported and shall not rely on the pipeline and its connections for support. Excessive stresses may be encountered when appurtenances are inadequately supported.

D. Installation of Tracer Wire.

- a. Blue tracer wires shall be approved by the engineer and placed no more than 6 inches above the top of pipe. If separate warning ribbon is used, it should be placed three feet or less below ground surface.
- b. The Contractor shall be required to install tracer wire along the entire section of pipeline and along all service connections as listed below. The tracer wire shall be installed simultaneously with the HDPE piping system. Tracer wires shall be properly spliced at each end connection and each service connection by use of splicing devices specifically designed and manufactured for underground electrical connections. Care should be taken to adequately wrap and protect wire at all splice locations. No bare tracer wire shall be accepted. Contractor shall verify tracer wire continuity prior to acceptance. Provide a sacrificial anode for cathodic protection of the tracer wire that conforms to the requirements of ASTM B843. Install tracer wire per local and manufacturer's requirements.
- c. Open Trench - Tracer wire shall be a minimum of #12 AWG solid Copper, Copper Clad Steel, or high-strength braided stainless steel with minimum 450 lb. break load, with a minimum 30 mil HDPE insulation thickness.

- d. Directional Drilling/Boring - Tracer wire shall be solid #12 AWG (or like #10), copper-clad steel or braided stainless steel (A316), Extra High Strength with minimum 1,150 lb. break load, and with minimum 45 mil HDPE insulation thickness (applies to all wires).
- e. Pipe Bursting/Sliplining - Tracer wire shall be 7 x 7 (or stronger) stranded copper-clad steel with 4,700 lb. breaking strength, or braided stainless steel (A316), with minimum 45 mil HDPE insulation thickness.

E. Embedment and Final Backfill:

- 1. See Appendix E-1 for trench terminology and Appendix E-2 for Basic Installation
- 2. Embedment material should be Class I, Class II, Class III, or Class IV soils, as defined by AWWA M55, except for the bedding material, which should be either Class I or Class II. Class V soils are not recommended. See Appendix F for Uniform Soil Classes.
- 3. The allowable maximum particle size in the embedment shall not exceed the values shown in Table 4.

Table 4: Allowable Maximum Particle Size in Embedment

Pipe Diameter	Particle Size
≤ 4"	≤ ½"
6" and 8"	≤ ¾"
10" to 16"	≤ 1"
≥ 18"	≤ 1.5"

- 4. The final backfill usually consists of the excavated trench material and should not contain any deleterious or hazardous material, organic matter, construction debris, or boulders. Class V soils should not be used for final backfill unless specifically required. If the final backfill is located beneath a paved surface, crossing pipeline, or waterway, the soil should be placed in lifts and compacted to ≥95% (ASTM D698), or in accordance with requirements of the owner or agency. Farmlands and steep slopes may have different requirements for compacted backfill. The maximum particle size should be 3 inches in consideration of future excavation.

- F. Cold (Field) Bending. Contractor shall not bend the pipe to fit a trench less than the radius shown in Table 5. The minimum long-term cold (field) bending radius shall be as follows:

Table 5: Minimum Long-Term Bending Radius per Pipe DR

Pipe DR	Minimum Cold Bending Radius (long-term)
≤ 9	20 x pipe OD
11 – 13.5	25 x pipe OD
17 – 21	27 x pipe OD
Fitting or Flange within bend	100 x pipe OD

- G. Separation: Separation of water mains, sewers, and other non-potable fluid-carrying pipelines shall be governed by the state or local responsible permitting agency.

In areas where the required separation cannot be obtained, it is recommended that either the waterline or the non-potable line is constructed of fusion welded HDPE pipe.

H. Trenchless Installations

1. This section is applicable for HDD and other pull-in installations.
2. Per ASTM F1804 and/or www.HDPEapp.com, the contractor shall determine and document the maximum proposed pull-in length and pull-in force for the pressure class and pipe diameter to be pulled into an open trench. Pull-in lengths will not exceed the maximum lengths for the class and diameter pipe.
3. Prior to pulling the pipeline, contractor shall place rollers or other approved devices beneath the pipe to avoid unnecessary damage and to reduce pipe drag. Sharp pavement corners on the launching pit must be avoided either by use of rollers or pads to avoid damage to pipe.
4. Per the manufacturer's recommendation, a commercially available load limiter (weak link) approved by the Engineer shall be used between the puller and the pipe. Appendix C.1 lists the Maximum Pull Force for PE4710 DIPS DR11/DR17 and for 12-hour pull duration; refer to HDPEapp.com for other conditions and other pull durations. Per ASTM F1804 and PPI PE Handbook, the maximum safe pull stress for PE4710 shall not exceed the values shown in Table 6:

Table 6: PE4710 (PE 445574) Safe Pull Tensile Stress
(Refer to Appendix C.1 for Safe Pull Force)

Load Duration	Safe Pull Stress at 80°F
½ hr. to 1 hr.	1400 psi
12 hrs.	1300 psi
24 hrs.	1250 psi

5. References:
 - i. For HDD, refer to ASTM F1962, MAB-7, MAB-11, PPI PE Handbook (Chp. 12) and www.ppiBoreAid.com
 - ii. For sliplining, refer to ASTM F585, PPI PE Handbook (Chp. 11) and www.HDPEapp.com
 - iii. For pipe bursting, refer to MAB-5 and PPI PE Handbook (Chp. 16)
 - iv. For compression-fit, refer to ASTM F3508

I. Water Service Pipes

- i. The minimum distance between service taps should be 24 inches to maintain space for future work. All new services shall be shown accurately on the record drawings and tied to existing property lines. Tracer wire shall be installed along with all new HDPE services per Section 4.3 E.
- ii. The minimum recommended pipe size of new and replacement water service lines is 1-inch (unless otherwise specified by the owner) PE4710 SDR 9 PC250.
- iii. Water services shall be installed with a minimum cover as measured vertically from the top of the pipe to finished grade. Where frost protection is not required, service shall be buried at least 18" deep. Where frost protection is required, refer to the local agency for burial depth.
- iv. Hydrant Assemblies shall be installed and field tested according to the requirements of AWWA M17.

- v. When replacing metallic service lines with HDPE, the electrical grounding system shall be maintained as required by the state or local responsible agency. It is the responsibility of the Owner to verify acceptable grounding requirements with the responsible agency and provide this information to the installer/contractor.

Note: NFPA 70 (National Electric Code) provides requirements for acceptable grounding systems, including the use of metal underground water pipe as a grounding electrode. The possible modification or reinstallation of the electrical grounding system may require a building permit, and the work is to be performed by a licensed electrical contractor. It may be acceptable to abandon the metallic service line in place, with any associated interior electrical connections undisturbed.

- vi. Refer to Appendix H for connecting 1 in. HDPE service line to HDPE water main.

PART 6: TESTING

- A. Conduct hydrostatic leakage testing per ASTM F2164.
- B. The test pressure shall be limited to a minimum of 1.5 x working pressure (and a maximum of 1.5 x PC- see Table 1) and shall not exceed the capacity of the lowest pressure rated and lowest elevation component.
- C. In a fused HDPE water piping system, no leakage is allowed.
- D. If the test fails, the test section shall be depressurized and allowed to 'relax' for at least eight hours before starting the next testing sequence.
- E. Leaks, failure or defective construction shall be promptly repaired by the Contractor at the Contractor's sole expense.
- F. The Contractor is responsible for the safety of their employees during the testing and repair.

PART 7: CLEANING AND DISINFECTING

- A. Cleaning and disinfecting of potable water systems shall be in accordance with AWWA C651.
- B. After installation, initial flushing and after completion of the pressure testing, new water mains should be disinfected in accordance with procedures outlined in AWWA C651 using solutions of liquid disinfectants (not powders or tablets).
- C. Upon verification of disinfection/purification, all service pipes, branch laterals, and distribution mains shall be thoroughly flushed with fresh potable water and retested to verify the disinfectant chlorine level has been reduced to potable drinking water concentrations suitable for human consumption.

APPENDIX A: BIBLIOGRAPHY

American Water Works Association, AWWA

www.awwa.org

1. ANSI/AWWA C600 Installation of Ductile-Iron Mains and Their Appurtenances
2. ANSI/AWWA C651 Standard for Disinfecting Water Mains
3. ANSI/AWWA C810 Replacement and Flushing of Lead Service Lines.
4. ANSI/AWWA C901 Polyethylene (PE) Pressure Pipe, Tubing, and Fittings, ¾ In. (19 mm) Through 3 In. (76 mm) for Water Service
5. ANSI/AWWA C906 Polyethylene (PE) Pressure Pipe and Fittings, 4 In. Through 65 In. (100 mm Through 1,650 mm), for Waterworks
6. AWWA M17 Fire Hydrants: Installation, Field Testing, and Maintenance
7. AWWA M55 PE Pipe—Design and Installation

Municipal Advisory Board, MAB

www.plasticpipe.org/MABpubs

1. PPI and MAB Position Paper on HDPE (PE 4710) Distribution Potable Water Pipe Sizes and Pressure Classes
2. MAB-01 MAB Generic Electrofusion Procedure for Field Joining of 12 Inch and Smaller Polyethylene (PE) Pipe
3. MAB-02 MAB Generic Electrofusion Procedure for Field Joining of 14 Inch to 30 Inch Polyethylene (PE) Pipe
4. MAB-03 MAB Model Specifications for PE4710 Buried Potable Water Service, Distribution and Transmission Pipes and Fittings
5. MAB-04 MAB Basic HDPE Repair Options
6. MAB-05 MAB Guidelines for PE4710 Pipe Bursting of Potable Water Mains.
7. MAB-06 MAB Guidelines for HDPE Pipeline Inspection
8. MAB-07 MAB Guidelines for Use of Mini-Horizontal Directional Drilling for Placement of HDPE (PE4710) Pipe in Municipal Applications
9. MAB-08 MAB Guidelines for Fusing HDPE Pipe in Cold and Inclement Weather
10. MAB-09 Design of HDPE Water Mains for the Lateral Spread Seismic Hazard
11. MAB-10 Design of HDPE Water Mains for the Fault Crossing Seismic Hazard
12. MAB-11 Model Specifications for Installation of PE4710 Water Service, Distribution, and Transmission by Horizontal Directional Drilling
13. Assessment and Calculation of BTEX Permeation Through HDPE Water Pipe, IUPUI, Purdue School of Engineering, Koo, D, July 2012
14. Fatigue of Plastic Water Pipe: A Technical Review with Recommendations for PE4710 Pipe Design Fatigue, JANA, May 2012
15. eTrenchless Software: PPI PACE, PPI BoreAid, HDPEapp
16. Anchor Blocks for HDPE Water Pipes, report to Plastics Pipe Institute, Irving, TX, Stewart, HE, Ö Bilgin, KE Kesner, MA Yerges, 2022
17. Seismic Response of HDPE Laterals, PPXX, Amsterdam O'Rourke, M., 2021
18. Design of HDPE Water Mains for the Lateral Spread Seismic Hazard, PPXXI, Florida, O'Rourke, M., 2023
19. Horizontal Directional Drilling – Estimating Pipe Pulling Tensions, Slavin, LM, Aug. 2022
20. Pipeline Installation 2.0, Relativity Publishing, Lakewood CO, Howard, Amster, 2015

Plastics Pipe Institute, PPI www.plasticpipe.org

1. PPI Handbook of Polyethylene Pipe
2. PPI Comments on Permeation of Water Pipes and on the AWWA-RF Report on Hydrocarbons
3. PPI TR-4 PPI Listing of Hydrostatic Design Basis (HDB), Hydrostatic Design Stress (HDS), Strength Design Basis (SDB), Pressure Design Basis (PDB) and Minimum Required Strength (MRS) Ratings for Thermoplastic Piping Materials or Pipe
4. PPI TR-34 Disinfection of Newly Constructed Polyethylene Water Mains
5. PPI TN-38 Bolt Torque for Polyethylene Flanged Joints
6. PPI TN-44 Long Term Resistance of AWWA C906 Polyethylene (PE) Pipe to Potable Water Disinfectants
7. PPI TN-49 Recommendations for AWWA C901 Service Tubes in Potable Water Applications
8. PPI TN-54 General Guidelines for Squeezing Off Polyethylene Pipe in Water, Oil and Gas Applications
9. GTI/PPI PE4710 Mitered Elbow Finite Element Analysis, 2016
10. GTI/PPI Hydrostatic Pressure Testing of PE4710 Fabricated Tees and Elbows, March 2026

Manufacturers Standardization Society, MSS

www.msshq.org MSS SP-60 Connecting Flange Joints between Tapping Sleeves and Tapping Valves

NSF International www.nsf.org NSF/ANSI 61 Drinking Water System Components—Health Effects

ASTM International www.astm.org

1. ASTM B843 Standard Specification for Magnesium Alloy Anodes for Cathodic Protection
2. ASTM D698 Standard Test Methods for Laboratory Compaction Characteristics of Soil Using Standard Effort.
3. ASTM D2487 Standard Practice for Classification of Soils for Engineering Purposes (Unified Soil Classification System)
4. ASTM D2683 Standard Specification for Socket-Type Polyethylene Fittings for Outside Diameter-Controlled Polyethylene Pipe and Tubing
5. ASTM D3261 Standard Specification for Butt Heat Fusion Polyethylene (PE) Plastic Fittings for Polyethylene (PE) Plastic Pipe and Tubing
6. ASTM D3350 Standard Specification for Polyethylene Plastics Pipe and Fittings Materials
7. ASTM F585 Standard Guide for Insertion of Flexible Polyethylene Pipe into Existing Sewer
8. ASTM F905 Standard Practice for Qualification of Polyethylene Saddle-Fused Joints
9. ASTM F1055 Standard Specification for Electrofusion Type Polyethylene Fittings for Outside Diameter Controlled Polyethylene Pipe and Tubing
10. ASTM F1668 Standard Guide for Construction Procedures for Buried Plastic Pipe
11. ASTM F1804 Standard Practice for Determining Allowable Tensile Loads for Polyethylene Gas Pipe During Pull-In Installation
12. ASTM F1962 Standard Guide for Use of Maxi-Horizontal Directional Drilling for Placement of Polyethylene Pipe or Conduit under Obstacles Including River Crossings
13. ASTM F2164 Standard Practice for Field Leak Testing of Polyethylene (PE) Pressure Piping Systems Using Hydrostatic Pressure

14. ASTM F2206 Standard Specification for Fabricated Fittings of Butt-Fused Polyethylene (PE) Plastic Pipe, Fittings, Sheet Stock, Plate Stock, or Block Stock
15. ASTM F2620 Standard Practice for Heat Fusion Joining of Polyethylene Pipe and Fittings
16. ASTM F2880 Standard Specification for Lap-Joint Type Flange Adapters for Polyethylene Pressure Pipe in Nominal Pipe Sizes 3/4 in. to 65 in.
17. ASTM F3124 Standard Practice for Data Recording the Procedure used to Produce Heat Butt Fusion Joints in Plastic Piping Systems or Fittings
18. ASTM F3183 Standard Practice for Guided Side Bend Evaluation of Polyethylene Pipe Butt Fusion Joint
19. ASTM F3190 Standard Practice for Heat Fusion Equipment (HFE) Operator Qualification on Polyethylene (PE) and Polyamide (PA) Pipe and Fittings
ASTM 3508 Standard Guide for In-Situ Pipeline Renovation as Dual-Wall Composite Pipeline by Push/Pull Installation of Compressed-Fit Shape-Memory-Polymer Tubular (SMPT)
20. ASTM F3565 Standard Practice for Electrofusion Joining Polyethylene (PE) Pipe and Fittings for Pressure Pipe Service

Other Related References

- PPI Polyethylene Piping Systems Field Manual for Municipal Water
- ASTM D2321 Standard Practice for Underground Installation of Thermoplastic Pipe for Sewers and Other Gravity-Flow Applications
- ASTM D2737 Standard Specification for Polyethylene (PE) Plastic Tubing
- ASTM D2774 Standard Practice for Underground Installation of Thermoplastic Pressure Piping
- ASTM F714 Standard Specification for Polyethylene (PE) Plastic Pipe (SDR-PR) Based on Outside Diameter
- ASTM F1041 Standard Guide for Squeeze-off of Polyolefin Gas Pressure Pipe and Tubing
- ASTM F1290 Standard Practice for Electrofusion Joining Polyolefin Pipe and Fittings
- ASTM F1417 Standard Test Method for Installation Acceptance of Plastic Gravity Sewer Lines Using Low-Pressure Air
- ASTM F1563 Standard Specification for Tools to Squeeze-off Polyethylene (PE) Gas Pipe or Tubing

APPENDIX B.1: ANSI/AWWA C906 PE4710 DIPS and IPS Pipe Sizes

Nominal Pipe Size, (inches)	Average Outside Diameter, (inches)	
	DIPS	IPS
NPS		
4	4.800	4.500
6	6.900	6.625
8	9.050	8.625
10	11.100	10.750
12	13.200	12.750
14	15.300	14.000
16	17.400	16.000
18	19.500	18.000
20	21.600	20.000
22	-	22.000
24	25.800	24.000
26	-	26.000
28	-	28.000
30	32.000	30.000
32	-	32.000
34	-	34.000
36	38.300	36.000
42	44.500	42.000
48	50.800	48.000
54	57.560	54.000
60	61.610	60.000
63	-	63.000
65	-	65.000

APPENDIX B.2: ANSI/AWWA C901 PE4710 CTS and IPS Pipe Sizes

Nominal Pipe Size, (inches)	Average Outside Diameter, (inches)	
	CTS	IPS
NPS		
$\frac{3}{4}$	0.875	1.050
1 (minimum recommended)	1.125	1.315
1 $\frac{1}{4}$	1.375	1.660
1 $\frac{1}{2}$	1.625	1.900
2	2.125	2.375
3	-	3.500

APPENDIX C: Safe Pull Force for PE4710 DIPS @ 80°F*

Nominal Pipe Size (in.)	Safe Pull Strength (lb.)	
NPS (sample list)	DIPS DR11	DIPS DR 17
4	7,956	5,330
6	16,440	11,013
8	28,282	18,946
10	42,546	28,502
12	60,168	40,306
14	80,835	54,151
16	104,548	70,036
18	131,306	87,962
20	161,110	107,927
24	229,856	153,980
30	353,603	236,877

***Note:** This Table is based on 12-hour pull. Refer to HDPEAPP.com for other pipe sizes, DRs, pull duration and other conditions.

APPENDIX D: Degradation of Gaskets with Chlorine and Chloramine

As with any system utilizing mechanical gasketed joints, including HDPE, consideration should be given to the proper selection of gaskets. As shown in ANSI/AWWA C111-17 (and in others such as C303-17 and C909-16), the “selection of materials is critical for water service and distribution piping in locations where there is a possibility that elastomers will be in contact with chlorine or chloramines. Documented research has shown that elastomers such as gaskets, ... may be degraded when exposed to chlorine or chloramines...” For more details, refer to AWWA C111, Special Issues and to the section titled Chlorine and Chloramine Degradation of Elastomers.

APPENDIX E-1: Trench Cross Section and Terminology

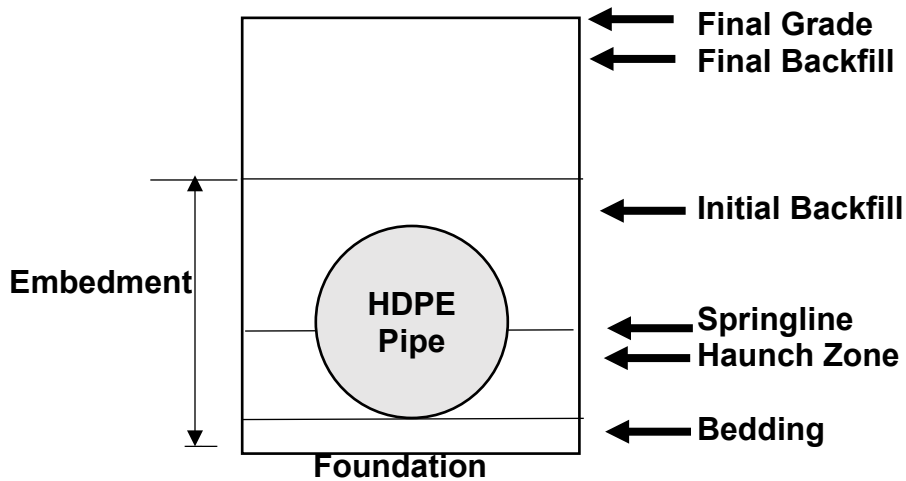

- **Foundation:** The foundation is the native soil at the bottom of the excavation. If the foundation is unsuitable, remediation will be required to provide a stable trench bottom.
- **Bedding:** The bedding is the soil placed in the bottom of the trench on top of the foundation. The bedding serves as a cushion for the pipe. The bedding shall be uncompacted and have a minimum thickness of 4 inches for pipe diameters less than 60 inches and 6 inches for pipe diameters of 60 inches or more.
- **Haunch Zone:** The haunch zone is from the bottom of the pipe up to the springline. The haunch zone and the initial backfill provide the side support for the pipe that limits deflection.
- **Springline:** The springline is the horizontal centerline of the pipe.
- **Initial Backfill:** The initial backfill extends from the top of the haunch zone to 12 inches above the top of the pipe.
- **Embedment:** The embedment includes the bedding, haunch zone, and initial backfill.
- **Final Backfill:** The final backfill extends from the top of the initial backfill to the final grade.

APPENDIX E-2: HDPE Basic Installation*

The use of the following Detail for HDPE Basic Installation requires the Engineer to verify all conditions as required in PPI PE Handbook, Chp. 7 (2025), starting on p. 7-6.

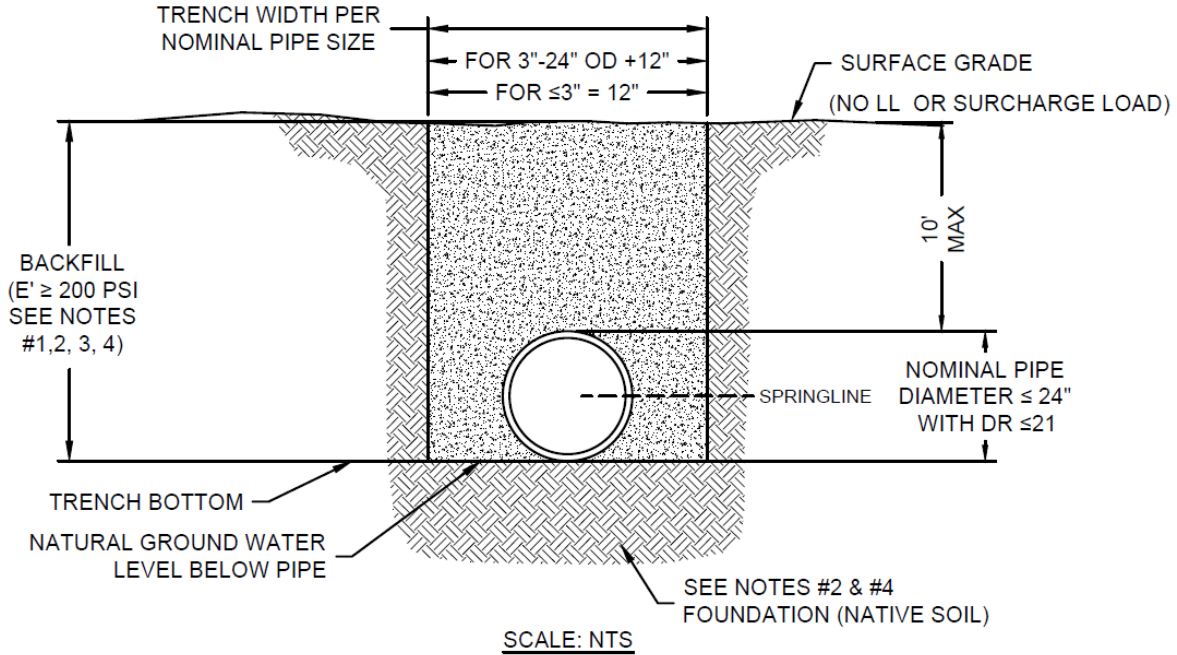

*ENGINEERED INSTALLATION MUST BE USED WHEN BASIC INSTALLATION CONDITIONS ARE NOT MET

NOTES:

1. BACKFILL NOT REQUIRED TO BE COMPACTED
2. FOUNDATION DOES NOT CONSIST OF EXPANSIVE CLAYS, COLLAPSING SOILS, OR LANDFILLS
3. MAX PARTICLE SIZE IN FOUNDATION AND BACKFILL (SEE TABLE BELOW)
4. DEFLECTION LIMIT FOR PRESSURIZED PIPE (SEE TABLE BELOW)

DR	Deflection Limits
21	7.5% OD
17, 13.5	6% OD
11	5% OD

Pipe Size, In.	Max. Particle Size, In.
≤ 4"	1/2"
6-8"	3/4"
10-16"	1"
16-24"	1 1/2"

APPENDIX F: Uniform Soil Classes

Table F-1: Soil Classes for Pipe Installation per AWWA M55

SOIL CLASS	DESCRIPTION OF SOIL	USCS SYMBOL
Class I	Crushed rock 100% passing 1-1/2-in sieve, ≤ 25% passing 3/8-in sieve, ≤ 15% passing #4 sieve, ≤ 12% fines	
Class II	Clean, coarse-grained soils or any soil beginning with one of these symbols (can contain up to 12% fines) (Note 1)	GW GP SW SP
Class III	Coarse grained soils with fines Sandy or gravelly fine-grained soils with ≥ 30% retained on #200 sieve	GM GC SM SC ML CL
Class IV	Fine-grained soils with < 30% retained on #200 sieve	ML CL
Class V	Fine-grained soils, organic soils high compressibility silts and clays, organic soil	MH CH OL OH Pt

Notes:

- i. Uniform fine sands (SP) (SP-SC) (SP-SM) with more than 50% passing a #100 sieve should be treated as Class III material.
- ii. Soil classification (Uniform Soil Classification System, USCS) in accordance with ASTM D2487 or ASTM D2488.
- iii. *Fines* are soil particles that pass a #200 sieve.
- iv. Class I: crushed rock particles should have all fractured faces.
- v. Recycled concrete and shells should be considered Class II.
- vi. Class V: Not recommended for embedment.
- vii. Reference: AWWA M55, PE Pipe- Design and Installation, 2nd edition, 2020

APPENDIX G: Sample Anchor Blocks

Figure G.1 illustrates an example of the reinforcement in the 8 in. HDPE DR 13.5 block (DIPS). Please note that the flex restraints are offset from the center to maximize effective depth of concrete for the punching shear.

Table G.1 shows examples of reinforced concrete anchor blocks for multiple HDPE (PE4710) DIPS SDR13.5 pipes. The block sizes are for working pressure equal to 70 psi and an Occasional Surge flow velocity of 8 ft/sec (see Table 2). Other conditions include Good Construction Practices in a cold temperature zone; see HDPEapp.com, PPI Handbook Chp. 7, Apdx A, and “Anchor Blocks for HDPE Water Pipes” for details and other conditions.

The restraint devices should be equally spaced around the pipe circumference. In this example, flexible electrofusion restraints are shown, but any restraining device with a capacity equal to or greater than the axial thrust due to internal pressure forces (Poisson) and thermal forces is acceptable.

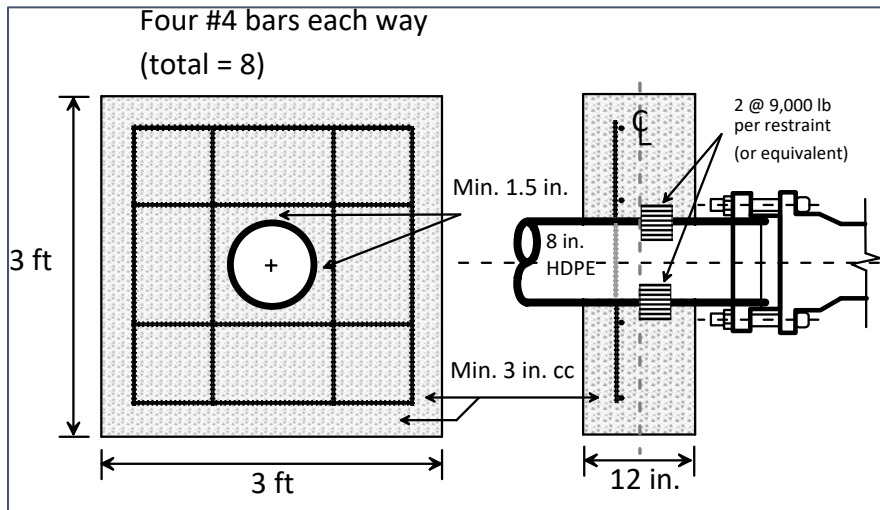

Figure G.1 Example: Reinforced concrete anchor block for an 8-in. HDPE DIPS DR 13.5 pipe

Table G.1. Examples for HDPE Anchor Blocks, Cold Temperature Zone, and Best Practices Construction [WP (70 psi) + Surge (8 ft/sec) See Table 2]

PE4710 DIPS DR 13.5 *	Block Size **	Total No. & Size of Steel Bars ***	No. of Flex Restraints at 9,000 lbs. / Restraint ****
6 in.	3 ft x 3 ft x 12 in.	8 #4 (4 each way)	1 (1 row)
8 in.	3 ft x 3 ft x 12 in.	8 #4 (4 each way)	2 (1 row)
12 in.	3.5 ft x 3.5 ft x 14 in.	12 #4 (6 each way)	3 (1 row)
16 in.	3.5 ft x 3.5 ft x 16 in.	8 #5 (4 each way)	5 (1 row)
24 in.	4.7 ft x 4.7 ft x 21 in.	8 #5 (4 each way)	10 (1 row)
30 in.	5.8 ft x 5.8 ft x 24 in.	16 #6 (8 each way)	15 (2 rows)
36 in.	6.8 ft x 6.8 ft x 27 in.	20 #6 (10 each way)	22 (2 rows)

*Refer to HDPEapp.com for IPS pipes, other HDPE pipe diameters, DRs, and operating conditions

**Minimum compressive strength of concrete, $f'_c = 5,000$ psi at pipe depth of 4 ft. to crown in “dense” conditions. When necessary, compact the soil to $\geq 95\%$ (ASTM D698) around the blocks.

*** Split equally horizontally and vertically. Steel bars are required for temperature and shrinkage. Users can refer to the American Concrete Institute Code (ACI 318-19, Chp. 14, Plain Concrete) for other options. Other steel bar sizes can be used- see HDPEapp.com.

**** Flex restraints are off set equally around the circumference to maximize effective depth of concrete for punching shear

APPENDIX H: 1" HDPE Water Service Connected to HDPE Mains

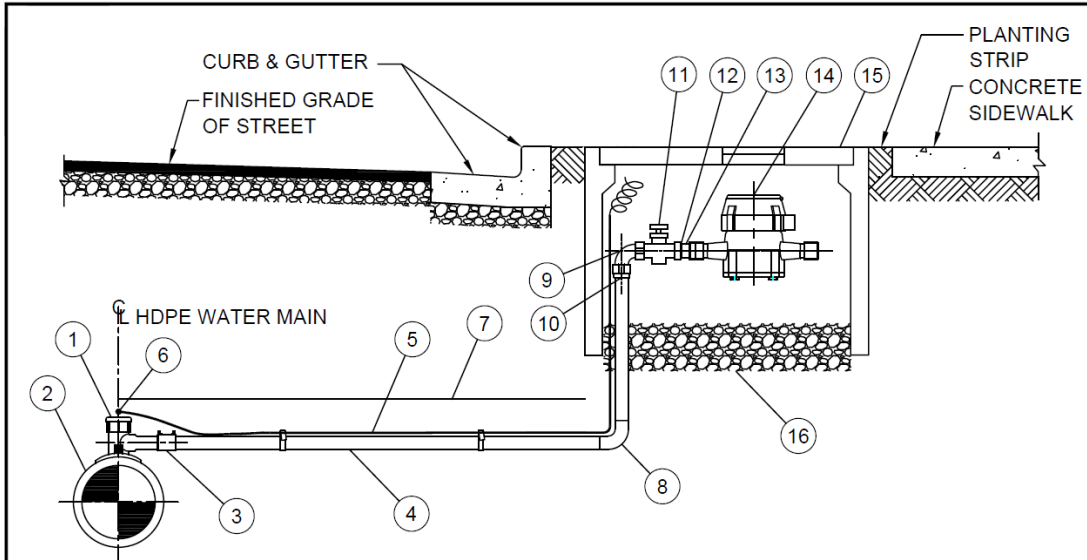

GENERAL NOTES:

1. ALL MATERIALS, CONSTRUCTION PROCEDURES AND APPURTENANCES SHALL CONFORM WITH EACH WATER AGENCY REQUIREMENTS AND SPECIFICATIONS HAVING JURISDICTION OVER THE INSTALLATION OF THE WATER SERVICES.
2. SERVICES SHALL BE CONTINUOUS WITH NO JOINTS FROM TAPPING TEE TO METER 90° BEND. MAB RECOMMENDS FUSING ALL CONNECTIONS BETWEEN POLYETHYLENE PIPING WHENEVER POSSIBLE.
3. PIPE FUSIONS SHALL BE CONDUCTED IN ACCORDANCE WITH APPLICABLE MAB AND INDUSTRY STANDARD PROCEDURES.
4. ALL BRASS FITTINGS SHALL BE COMPRESSION WITH LINER/STIFFENER PER MANUFACTURER RECOMMENDATIONS.
5. WATER TRACER WIRE SHALL BE INSTALLED DIRECTLY ABOVE THE WATER SERVICE AND TAPED EVERY 20' (FEET) WITH POLY TAPE.
6. MAIN TRACER WIRE CONNECTION SHALL BE WITH CONNECTORS INTENDED FOR UNDERGROUND USE AND INCLUDE SEALING BY TAPING OR ENCAPSULATION.
7. WATER WARNING TAPE SHALL BE PLACED 6" MINIMUM ABOVE WATER SERVICE.
8. PROVIDE CATHODIC PROTECTION ON ALL ISOLATED TRACER WIRE SYSTEMS AS REQUIRED.
9. FOR MAIN SIZES 12" AND GREATER BRANCHING SADDLES MAY BE REQUIRED TO ALLOW HOT TAPS.

ITEM	SIZE & DESCRIPTION	ITEM	SIZE & DESCRIPTION
1	SIZE x 1" ELECTROFUSION TAPPING TEE	10	1" STIFFENER FOR HDPE SDR 9 PIPE
2	SIZE HDPE WATER MAIN AWWA C906	11	1" CURB STOP - CHECKLESS 360° TURN
3	1" ELECTROFUSION COUPLING	12	1" x 3/4" BRASS REDUCER BUSHING ADAPTER FOR 5/8"x3/4" METERS
4	1" HDPE 4710 SDR 9 WATER PIPE AWWA C901	13	3/4" STRAIGHT METER COUPLING FOR 5/8" METERS OR 1" COUPLING FOR 1" METERS. USE 1/8" POLYETHYLENE GASKETS.
5	COPPER TRACER WIRE, 10 AWG TYPE HMW	14	WATER METER BY WATER AGENCY
6	TRACER WIRE MAIN SPLICE CONNECTOR	15	METER BOX AND COVER PER UTILITY STANDARDS
7	WATER WARNING TAPE	16	1" DRAIN ROCK. 6" MIN. DEEP
8	1" 90° ELL, SOCKET OR ELECTRO FUSION		
9	1" BRASS 90° BEND, COMPRESSION BY THREAD		

**1" HDPE WATER SERVICE
CONNECTED TO HDPE MAINS**

MAB DETAILS

COMMITTEE APPROVAL:
NOVEMBER 20, 2025

SCALE: NONE

DRAWING NUMBER:
WS-01

REVISION:

APPENDIX I: HDPE Top 10 Features and Benefits

PE4710 HDPE PIPE: *The Best Choice for Water Systems*

TOP 10 Features & Benefits		HDPE	D. Iron
1	Applications: Potable Water (Lead Free), Raw Water, Reclaimed Water, and Wastewater	✓	✓
2	Open Cut Construction: Design and install per AWWA Standards and Manuals	✓	✓
3	Trenchless Construction: Material of choice for HDD, Pipe Bursting (Pneumatic + Static), Sliplining, and Compression Fit	✓	✗
4	Fully Restrained Joint-Free System: Minimize need for fittings to facilitate horizontal and vertical deflections eliminating the need for thrust blocks	✓	✗
5	Longevity & Corrosion: Pipes, Fittings, and Joints have the least potential for corrosion or tuberculation	✓	✗
6	Flow Capacity: New pipes have similar flow capacity per AWWA Standards and Manuals	✓	✓
7	Water & Energy Conservation: Fused Joints have zero allowable water leakage and zero Infiltration	✓	✗
8	Cost Effective: Has the lowest initial cost, lowest life cycle cost, and lowest restoration cost for trenchless installations	✓	✗
9	Resilient: Ability to resist water hammer and ground movements due to droughts, freeze/thaw, earthquakes, and hurricanes with the ability to control flow with squeeze-off	✓	✗
10	Permeation/BTEX: In contaminated conditions, pipes and elastomeric joints require proper engineering.	✗	✗

Sample References

- [AWWA C901, AWWA C906, AWWA C151, NSF 61, NSF 2024 Health Effects of HDPE Pipes and Fittings for Potable Water Applications](#)
- [AWWA M55, AWWA M41, MAB-3, MAB-6](#)
- [ASTM F585, ASTM F1962, ASTM F3508, MAB-5, MAB-7, MAB-11](#)
- [AWWA M55, AWWA M41](#)
- [NACE 2019 Corrosion Management in the Water Treatment Sector, PPIPACE.com, UKWIR 2020 Long-Term Aging of Polyethylene Pipes](#)
- [AWWA M55, AWWA M41 and PPIPACE.com](#)
- [AWWA M55, AWWA M41, ASTM F2620, ASTM F3190, ASTM F3565, MAB-1, MAB-2, MAB-8](#)
- [CSIRO 2008 Life Cycle Analysis of Water Networks, Annual Drinking Water Quality Report for 2014, Kittery Water District, 5/31/15](#)
- [WRF 2012 Recent Earthquakes: Implication for U.S. Water Utilities, Kubota 2018 Polyethylene Pipeline Performance Against Earthquake, MAB-9, MAB-10](#)
- [AWWA C901, AWWA C906, AWWA C111, AWWA C151, Sec 4](#)