

Plastic Piping Materials for Geothermal/Geoexchange Heating and Cooling Applications

TN-55

2018

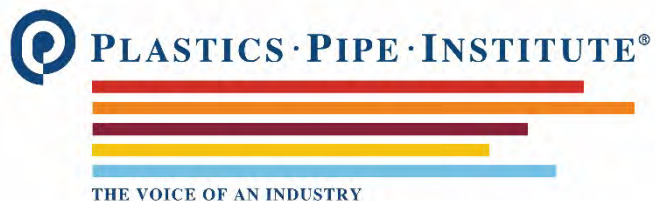

Foreword

PLASTIC PIPING MATERIALS FOR GEOTHERMAL/GEOEXCHANGE HEATING AND COOLING APPLICATIONS

This technical note was developed and published with the technical help and financial support of the members of the Plastics Pipe Institute (PPI). These members have shown their commitment to developing and improving quality products by assisting standards development organizations in the development of standards, and also by developing design aids and reports to help engineers, designers, code officials, specifying groups, contractors and users.

The purpose of this technical note is to provide information regarding the types of plastic piping materials used in ground-source geothermal/geoexchange heating and cooling applications, including various types of designs and installations, as well as information on appurtenances such as headers and manifolds.

The PPI has prepared this technical note as a service to the industry. The information in this document is offered in good faith and believed to be accurate at the time of its preparation, but is offered “as is” without any express or implied warranty, including **WARRANTIES OF MERCHANTABILITY AND FITNESS FOR A PARTICULAR PURPOSE**. Additional information may be needed in some areas, especially with regard to unusual or special applications. Consult the manufacturer or material supplier for more detailed information. A list of member manufacturers is available on the PPI website. PPI does not endorse the proprietary products or processes of any manufacturer and assumes no responsibility for compliance with applicable laws and regulations.

PPI intends to revise this technical note within five years or sooner if required, from the date of its publication, in response to comments and suggestions from users of the document. Please send suggestions of improvements to the address below. Information on other publications can be obtained by contacting PPI directly or visiting our website.

The Plastics Pipe Institute Inc.

www.plasticpipe.org

This Technical Note, TN-55, was first issued in March 2018.

© The Plastics Pipe Institute, Inc. 2018

PLASTIC PIPING MATERIALS FOR GEOTHERMAL/GEOEXCHANGE HEATING AND COOLING APPLICATIONS

1.0 INTRODUCTION

Geothermal or geexchange heating and cooling systems, also referred to as “ground source”, “ground-coupled” or “earth energy” heat pump systems, are “...self-contained, electrically-powered systems that take advantage of the Earth's relatively constant, moderate ground temperature to provide heating, cooling, and domestic hot water more efficiently and less expensively than would be possible through other conventional heating and cooling technologies” according to IGSHPA, the *International Ground Source Heat Pump Association*.

The three primary categories of geothermal or geexchange heating and cooling systems are commonly referred to as closed-loop, open-loop and direct-exchange:

- Closed-loop systems utilize plastic piping systems for the ground-coupled heat exchanger piping system, and are the primary focus of this technical note.
- Open-loop systems utilize ground water or surface water for the purpose of extracting or rejecting heat, as the water is circulated through a mechanical heat pump. While open-loop systems utilize the types of plastic pipes included in this Technical Note, these systems are not the focus of this document.
- Direct-exchange systems utilize copper tubing embedded in the ground with refrigerant circulating directly within this buried copper tubing. These systems will not be addressed in this Technical Note.

1.1 Closed-Loop Geothermal Systems

Closed-loop geothermal systems utilize plastic pipes and fittings that are buried in the ground in a variety of configurations, or submerged in water. The network of pipe and fittings, sometimes referred to as the *ground-coupled heat exchanger*, or simply the *ground loop*, is usually connected to a mechanical fluid-source heat pump unit¹. The ground-coupled heat exchanger is the thermal energy source during heating cycles and the thermal sink during cooling cycles.

A basic closed-loop geothermal or geexchange system typically includes:

- 1.1.1 Mechanical Components: Packaged mechanical heat pump with integrated electronic controls, circulating pumps and valves, typically installed indoors

¹ In special circumstances, direct heat-transfer systems may be designed without a mechanical heat pump or with the ability to bypass the heat pump, whereby the same fluid that passes through the ground heat exchangers also passes through the hydronic distribution pipe (e.g. a radiant heating or cooling slab). The fluid is moved by an electrical circulating pump.

1.1.2 Ground-Coupled Heat Exchanger Piping: Plastic pipe and fittings which are:

- Buried in a horizontal plane (e.g. trenches)
- Dropped in a vertical configuration (e.g. boreholes)
- Installed in a vertical large diameter hole (e.g. helix)
- Drilled or pushed into an angled configuration (e.g. inclined)
- Submerged in a surface body of water (e.g. pond, lake)
- Encased in structural building piling systems (e.g. energy piles)

1.1.3 Heat Transfer Fluid: Water, water/antifreeze solution, or brine solution

This Technical Note will provide relevant information on each of these categories, with a focus on ground loop piping materials. Other terms for a ground loop heat exchanger are the “ground loop” or the “source heat exchanger”.

2.0 MECHANICAL COMPONENTS

Mechanical components (i.e. heat pumps) should be designed and certified for closed-loop ground-coupled heating and cooling applications, and meet the requirements of all applicable codes and regulations.

Water-to-air heat pumps are typically connected to ducted air distribution systems within a building.

Water-to-water heat pumps are typically connected to hydronic distribution systems within a building. A hydronic system is a heat distribution/absorption system in which the final heat-transfer medium is a fluid such as water. Examples include radiant heating, radiant cooling, baseboard radiators, panel radiators, fan-assisted convectors, and ducted fan coils, which transfer the heat energy to/from the distribution air.

Water source heat pumps should be certified in accordance with AHRI/ASHRAE ISO Standard 13256-1 for water-to-air heat pumps, and AHRI/ASHRAE ISO Standard 13256-2 for water-to water heat pumps.

Circulating pumps, often packaged as tandem units with integrated connections, fill ports, etc. (also known as flow centers) are designed, built and sized specifically for the ground loop network and heating/cooling loads of each geothermal system.

3.0 GROUND-LOOP HEAT EXCHANGE PIPING SYSTEMS - INTRODUCTION

The ground-coupled heat exchanger piping system (i.e. the ground loop) may be designed to supply the total heating and cooling capacity of the building for the specific geographical location, or for partial loads. Partial-load heating systems are often supplemented with heat sources such as boilers or thermal solar collection systems. Partial-load cooling systems are often supplemented with mechanical chillers or cooling towers. In such situations, it is common for the geothermal systems to be sized to carry a base building load, typically 60 to 75% of the peak load, and for the supplement equipment to operate only when needed to meet peak loads.

The piping material is critical to the overall success of the closed-loop ground-coupled system and must provide corrosion resistance, chemical resistance, flexibility, impact resistance, resistance to slow crack growth, long-term hydrostatic strength (pressure capability), and temperature resistance. In addition, the ground loop heat exchanger materials must provide suitable heat transfer capabilities.

These piping systems may experience changes in pressure up to 60 psig (415 kPa), due to thermal expansion and contraction of the heat transfer fluid and the pipe itself over a potential operating temperature range from 25°F to 115°F (-4°C to 46°C).

Pressure and temperature cycles occur, to some degree, each time the system is operated. The typical average static pressure within the piping system at ground level is 25 psig to 40 psig (170 kPa to 275 kPa).

Typical plastic piping materials for ground loops are:

- HDPE: *High-density polyethylene*
- PEX: *Crosslinked polyethylene*
- PE-RT: *Polyethylene of raised temperature*
- PP: *Polypropylene pressure pipe*

Each of these plastic piping materials provides important long-term performance benefits for geothermal applications, including:

- a. Corrosion resistance
- b. Chemical resistance
- c. Flexibility
- d. Impact resistance
- e. Temperature resistance
- f. Long-term hydrostatic strength (pressure capability)

While all of these materials share common benefits for geothermal applications, each material has specific characteristics that influence their selection for various projects.

See Section 4.0 GROUND-LOOP HEAT EXCHANGE PIPING SYSTEMS - MATERIALS for additional information on these piping materials.

3.1 Ground-Loop Heat Exchange Piping Systems – System Types

Qualified designers should be involved with calculations and layouts for all ground-loop heat exchange system designs. Proper designs will determine the size and quantity of pipes which are required to meet design loads (in BTU, kW or tons of energy) for a specific system.

Designers often use specialized software modelling programs to ensure that heat exchange capacities will be satisfied by the ground loop piping design, even modelling the heat exchange for several years of operation to avoid overheating or overcooling the earth over time.

For a given project, the selected type of installation can be affected by several factors, such as:

- Topography and geography of the land (type of soil, amount of overburden, hills, valleys, water table, etc.)
- The type of equipment available to the installer
- Accessibility for equipment
- Available land area
- Water table levels
- Proximity to body of water
- Local regulations
- Other factors

Ground-loop heat exchange piping systems include, but are not limited to, the following installation types:

3.1.1 Horizontal Piping Systems

A horizontal piping system is typically buried at depths of 4 to 7 feet (1.2 to 2.1 m) within trenches, usually below the frost line for the location. Pipe spacing and positioning varies on factors such as soil type, thermal conductivity of the earth, width of the trench and other factors. Trench width can vary from just 2 ft. to 8 ft. (0.6 to 2.4 m) or more, depending upon factors such as the topography, soil type, equipment availability, etc.

Trench safety during installation of the pipe is an important consideration when designing trenches, and local regulation must be adhered (e.g. OSHA trenching and excavation safety requirements in 29 CFR 1926.651 and 1926.652). The amount of pipes and spacing between pipes installed within trenches can also vary.

3.1.2 Vertical Piping Systems

For vertical systems, flexible plastic pipes can be fabricated or formed into U-bend configurations using fused joints, mechanical fittings or jointless hot-forming techniques. Pipe U-bends are lowered into vertical boreholes, and then grouted² from the bottom to the top of the borehole with a grouting material selected for factors such as safety for contact with water aquifers, thermal conductivity, pumpability, non-permeability, and other environmental factors.

Typical borehole depths range from 50 to 600 feet (15 m to 182 m), and even deeper in certain projects using improved drilling technology. In some cases, vertical boreholes may extend into or through water aquifers that serve as sources for residential or municipal potable water systems.

Both single U-bend and double U-bend configurations are available. Double U-bends can increase the thermal performance of a borehole. See **Figures 1a & 1b**.

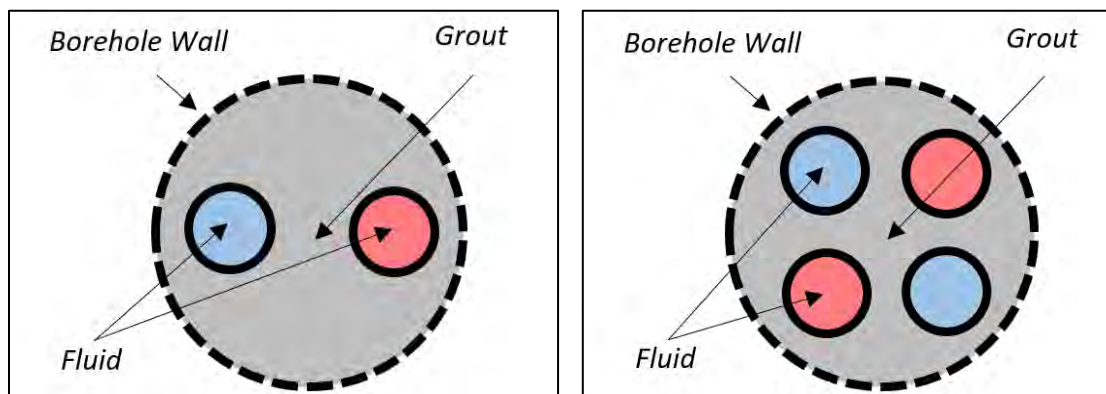

Figure 1a & 1b: Cross section of Single U-bend and Double U-bend Vertical heat exchangers

3.1.2.1 In deep vertical boreholes, ground-loop piping designers are often concerned about the static pressure of the fluid exceeding the pressure rating of the pipe itself, because substantially greater pressures can occur at the bottom of vertical piping loops. This can also occur when piping loops are connected to high-rise buildings.

² Grout is a bentonite material or fluid mixture, pumped into annular cavities between pipes and the earth, to seal the cavity. Grout material is usually mixed onsite and pumped into the borehole, from the bottom to the top, using an open-ended pipe known as the Tremie pipe. The functions of grout are: protection of groundwater supply; to prevent groundwater migration between aquifers; for heat transfer between pipes and borehole walls; and to prevent upward leakage from aquifers. Proper grout materials allow movement of the pipes and do not shrink or create voids. Approved grout materials and their placement are typically controlled by local/state/provincial regulations.

For example, when the fluid is water, the static pressure applied to fluid within the piping system is equivalent to 4.3 psig per 10 ft. (30 kPa per 3 m) of elevation, or 43 psig per 100 ft. (300 kPa per 30 m) of elevation. For antifreeze fluids with higher densities, this value is incrementally higher.

However, in a properly grouted borehole, the pressure of the grout surrounding the pipe will balance the static pressure of the fluid inside. In some installations, pipes pass through an aquifer, in which case the water surrounding the pipe balances the static pressure of the fluid inside.

3.1.3 Pipe-in-Pipe Coaxial Vertical Systems

Instead of placing two vertical pipes adjacent to each other connected with a U-bend at the bottom of the borehole, a pipe-in-pipe coaxial vertical system utilizes one pipe inside a larger vertical pipe in a concentric arrangement. See **Figure 2**.

There are several configurations available for this type of installation, but the objective is to improve the thermal performance of a vertical borehole by increasing the surface area of the external larger coaxial pipe, and therefore, reducing borehole thermal resistance of heat transfer from the ground to the pipe's surface. Installation techniques are different, as compared to the continuous pipe loops typically used in vertical boreholes, and borehole diameters may need to be larger to accommodate the external pipe.

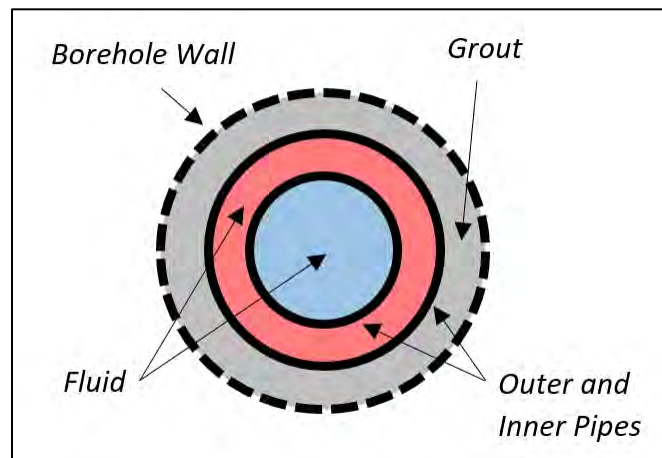

Figure 2: A cross section of a Coaxial heat exchanger (not to scale)

3.1.4 Helix Piping Systems

Certain project sites are neither ideal for horizontal systems nor traditional vertical boreholes, but may be suitable for helix piping systems. A helix system uses a wide borehole which is augured into the ground, typically 2 to 3 feet (0.6 to 0.9 m) in diameter and 16 to 20 ft. (4.9 to 6.1) deep. After the hole is dug, a tightly wound coil of pipe in a helix configuration is stretched-out into the hole.

Normally, the pipe is backfilled with native soil mixed with water for natural compaction. No grouting is used. Helix piping systems may be suitable where there is up to 20 ft. (6.1 m) of loose overburden (e.g. soil) above a rocky substrate, or where environmental regulations or other technical factors restrict drilling traditional boreholes deeper than 20 ft., for instance. See **Figure 3**.

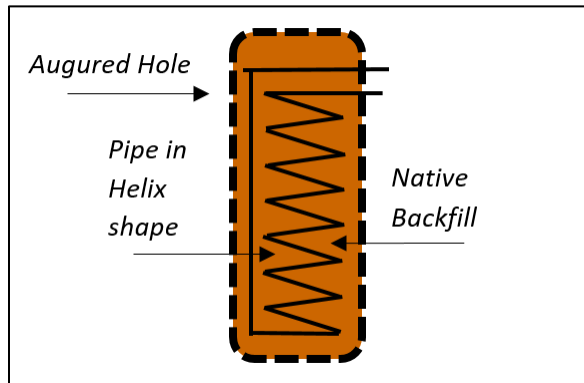

Figure 3: Side-view of a Helix piping system heat exchanger (not to scale)

3.1.5 Inclined or Angled Configurations

For project sites that may have limited access at the ground surface for multiple vertical boreholes, inclined or angled configurations involve drilling several intentionally non-vertical boreholes at angles from a common entry point, or nearby entry points. Some installers have innovated hydraulic ram devices that, in certain soft soil conditions, will push piping U-bends into the earth without predrilling boreholes. This process avoids grouting requirements, as the native soil reinstates itself around the heat exchange pipes. The pushing of the pipes from a common entry point may be done at various inclined angles. See **Fig. 4**.

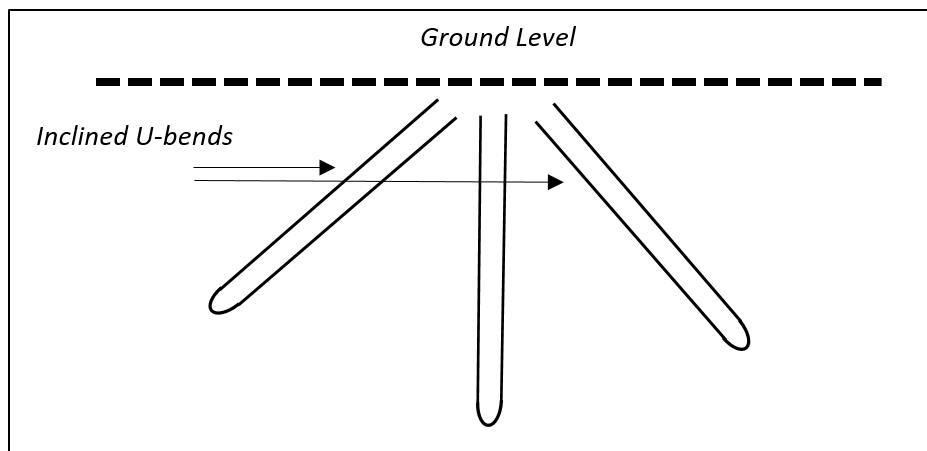

Figure 4: Side-view of an Inclined piping system heat exchanger (not to scale)

3.1.6 Horizontal Directional Drilling (HDD)

Horizontal Directional Drilling (HDD) is a technique for installing various types of pipes below ground using a surface-mounted drill rig that launches and places a drill string at a shallow angle to the surface and has tracking and steering capabilities.

The drill string creates an initial (pilot) bore hole of several inches diameter in an essentially horizontal path or shallow arc, which may be enlarged during a secondary operation, or sequence of such operations, through use of a reamer.

The predetermined path of the bore is maintained by tracking the path of the pilot bore using a manually operated overhead receiver or a remote (wireline or wireless) tracking system, and performing steering and path corrections by controlling the orientation of the drill head. Soil penetration is accomplished using high pressure, low volume fluid jets and/or mechanical cutting. The drilling fluid serves several purposes, including stabilization of the bore hole, removal of cuttings, lubrication for the drill string and product pipe, and cooling the drill head and transmitter electronics. Typically, the resultant slurry created by the combination of the drilling fluid and soil cuttings gradually solidifies into a solid mass encapsulating the product pipe.

Plastic ground loop pipe is typically installed during the final reaming operation, or, if necessary, as a separate, last step in the process.

Horizontal Directional Drilling can be suitable for geothermal ground loop pipes, and allows horizontal placement of the pipes at depths greater than open trenching, without disruption of the surface. Depending on soil types and the installer preference, plastic pipes can be installed individually and then connected where exposed at ground level (or in pits). Also, ground loops with integrated U-bends (fused, formed or permanent mechanical attachments), may be installed together in one horizontal borehole.

Note 1: See PPI TR-46 *Guidelines for Use of Mini-Horizontal Directional Drilling for Placement of High Density Polyethylene Pipe* for more information on Horizontal Directional Drilling.

3.1.7 Energy Piles

A pile or piling is a vertical structural element of a deep foundation, driven or drilled deep into the ground at a building site, used to transfer the weight of a building to solid earth. Piles are often used where the top layer of soil cannot support the weight of a building. Depths can range from 20 to 150 ft. (6 to 45 m).

Typically used in larger commercial applications where structural pilings are used for building support, geothermal pipes are sometimes installed within structural pilings to exchange energy with the

surrounding earth. The geothermal heat exchange pipes are fastened to structural steel rebar in circular or vertical patterns before the steel rebar “cages” are dropped into the holes. The concrete around the steel transfers the weight of the building to the earth, and helps to exchange heat from the embedded plastic pipes with the surrounding earth.

3.1.8 Submerged Piping Systems

In submerged piping systems, the piping network is submerged in a body of water (e.g. lake, pond, large tank or seawater) that is capable of handling the thermal rejection and extraction load of the application. Since the density of plastic piping materials is slightly less than water, the piping system must be weighted with ballast to avoid floating, and to hold it on or near the bottom of the water. Pipes used in these installations should be installed deep enough to avoid water that will freeze.

Care must also be taken that sediment, silt, or growths such as algae do not cover the pipes, as this would reduce heat transfer to the surrounding body of water. This body of water may, in some cases, also be the water source for a public or private water system.

Prior to design of any geothermal system, consult local/state/provincial regulations which may dictate or prohibit certain types of installations, including the depth of excavating or drilling, borehole design (e.g. diameter), casing requirements (for some vertical systems), the type of pipe permitted for use, and grouting requirements such as the depth of grout required and the type of grout permitted for use.

Industry standards, codes and local/state/provincial regulations will require all below-grade connections to be joined using heat fusion or approved mechanical fittings. The designer and installer should be knowledgeable of and proficient in the joining procedures recommended by the pipe and fittings manufacturer.

Industry standards, codes and local/state/provincial regulations will often specify which types of heat transfer fluid/s are permitted for use in the specific jurisdiction or location.

Note 2: See Section 6.0 HEAT TRANSFER FLUID for more information on fluids.

4.0 GROUND-LOOP HEAT EXCHANGE PIPING SYSTEMS - MATERIALS

The piping material is critical to the overall success of the closed-loop ground-coupled system and must provide corrosion resistance, chemical resistance, flexibility, impact resistance, resistance to slow crack growth, long-term hydrostatic strength (pressure capability), and temperature resistance. In addition, the ground loop heat exchanger materials must provide suitable heat transfer capabilities.

The following plastic piping materials for ground loops are described below:

- 4.1 HDPE: *High-density polyethylene*
- 4.2 PEX: *Crosslinked polyethylene*
- 4.3 PE-RT: *Polyethylene of raised temperature*
- 4.4 PP: *Polypropylene pressure pipe*

Each of these piping materials delivers long-term reliability proven over decades of use around the world. Piping materials are specified through rigorous product standards with detailed testing requirements for materials and performance, as well as strict industry certification programs to ensure consistent quality control. Relevant product standards are listed within Section 7.0 STANDARDS, CODES and REGULATIONS.

The life expectancy of these plastic piping materials, when specified correctly and installed according to industry and manufacturers' guidelines, is typically well in excess of fifty (50) years. Long-term pressure ratings for these piping materials are developed based on testing in accordance with **ASTM Test Method D2837**, and materials are listed according to **PPI TR-3**.

4.1 HDPE: High-Density Polyethylene

High-density polyethylene (HDPE) is the most common type of piping material used for ground heat exchangers, with decades of proven service for this application. It is recognized in virtually all codes and standards as an approved material for ground-coupled heat exchange piping systems.



Figure 5: Coil of HDPE piping with molded HDPE U-bend already fused to pipe ends

PPI recommends that all HDPE piping components used for ground-coupled heat exchangers meet the requirements of industry standard ANSI/CSA/IGSHPA C448, and:

- 4.1.1 Be a high-density polyethylene extrusion compound with a pipe material designation code of PE 3608³, PE 3710⁴, PE 4608⁴, PE 4708⁴, or PE 4710, and a color and ultraviolet stabilizer code of C or E, per ASTM D3350.
- 4.1.2 Be listed as such by the Plastics Pipe Institute’s Hydrostatic Stress Board (HSB) in PPI TR-4 with the minimum Hydrostatic Design Stress (HDS) value of 800 psi at 73°F (23°C).
- 4.1.3 Meet the requirements of NSF/ANSI Standard 358-1.
- 4.1.4 Meet the requirements of NSF/ANSI Standard 61 for open-loop systems, or if the water aquifer or reservoir into which the piping system is installed is a water source for a potable water system.

See **Table 1** for typical pressure ratings of some HDPE material grades and wall types.

Table 1: Minimum Pressure Ratings for Typical HDPE Geothermal Pipe

PE Material	DR	Pressure rating @ 73°F	Pressure rating @ 140°F
PE 3608	9	200 psi (1.4 MPa)	100 psi (0.7 MPa)
PE 3608	11	160 psi (1.1 MPa)	80 psi (0.6 MPa)
PE 3608	13.5	125 psi (0.9 MPa)	64 psi (0.4 MPa)
PE 4710	9	250 psi (1.7 MPa)	160 psi (1.1 MPa)
PE 4710	11	200 psi (1.4 MPa)	125 psi (0.9 MPa)
PE 4710	13.5	160 psi (1.1 MPa)	100 psi (0.7 MPa)
PE 4710	17	125 psi (0.9 MPa)	80 psi (0.6 MPa)

See also other PPI publications on PE materials, such as PPI’s *Handbook of Polyethylene Pipe*, Chapter 13 “HVAC Applications”.

³ PE 3608 meets the minimum requirements of ANSI/CSA/IGSHPA C448. Other PE material designation codes listed exceed the minimum requirements.

⁴ Not all material formulations are readily available in all markets and regions. The most common HDPE materials available at the time of this publication are PE 3608 and PE 4710.

4.2 PEX: Crosslinked Polyethylene

Crosslinked polyethylene (PEX) is a high-temperature, flexible pressure pipe with over 40 years of successful use in the European market, including extensive testing for durability and material performance. It was first introduced in North America in the early 1980s and is widely used for plumbing, water service, fire protection, hydronic heating and cooling, snow and ice melting and ground source geothermal piping systems.

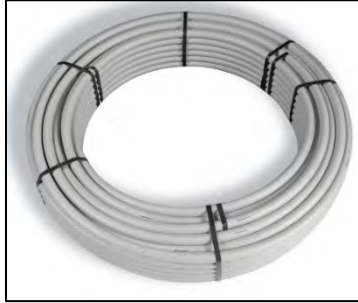

Figure 6: Coil of PEX Tubing

PPI recommends that all PEX piping components used for ground-coupled heat exchangers meet the requirements of industry standard ANSI/CSA/IGSHPA C448 and:

- 4.2.1 Be a crosslinked polyethylene compound with a pipe material designation code of PEX 1206⁵, PEX 1306, PEX 3206, PEX 3306, PEX 5206 or PEX 5306 per ASTM F876 and CSA B137.5.
- 4.2.2 Be listed as such by the Plastics Pipe Institute's Hydrostatic Stress Board (HSB) in PPI TR-4 with a minimum Hydrostatic Design Stress (HDS) value of 630 psi and a minimum pressure rating of 160 psi (1,100 kPa) at 73°F (23°C).
- 4.2.3 Meet the requirements of ASTM F876 or CSA B137.5.
- 4.2.4 Meet the requirements of NSF/ANSI Standard 358-3.
- 4.2.5 Meet the requirements of NSF/ANSI Standard 61 for open-loop systems, or if the water aquifer or reservoir into which the piping system is installed is a water source for a potable water system.

Note 3: A PEX compound will also be listed by PPI's Hydrostatic Stress Board with a minimum Hydrostatic Design Basis (HDB) value of 800 psi at 180°F (82°C).

See also other PPI publications on PEX materials, such as PPI TN-17 "Crosslinked Polyethylene Pipe & Tubing".

⁵ PEX 1206 meets the minimum requirements of ANSI/CSA/IGSHPA C448. Other PEX material designation codes listed exceed the minimum requirements.

4.3 PE-RT: Polyethylene of Raised Temperature

Polyethylene of raised temperature (PE-RT) is high-density polyethylene material with enhanced capabilities to withstand higher temperatures. PE-RT has a 35-year history of successful use in the European market with extensive testing for durability and material performance. It was first introduced in North America in 2003.



Figure 7: Coil of PE-RT Tubing

PPI recommends that all PE-RT piping components used for ground-coupled heat exchangers meet the requirements of industry standard ANSI/CSA/IGSHPA C448 and:

- 4.3.1 Be a high-density polyethylene extrusion compound with a pipe material designation code of PE 3608⁶, PE 3710⁷, PE 4608⁷, PE 4708⁷, or PE 4710, and a color and ultraviolet stabilizer code of C or E, per ASTM D3350, ASTM F2623 or ASTM F2769.
- 4.3.2 Be listed as such by the Plastics Pipe Institute's Hydrostatic Stress Board (HSB) in PPI TR-4 with the minimum Hydrostatic Design Stress (HDS) value of 630 psi at 73°F (23°C) and a minimum pressure rating of 160 psi (1,100 kPa) at 73°F (23°C).
- 4.3.3 Meet the requirements of ASTM F2623, ASTM F2769 or CSA B137.18.
- 4.3.4 Meet the requirements of NSF/ANSI Standard 358-4.
- 4.3.5 Meet the requirements of NSF/ANSI Standard 61 for open-loop systems, or if the water aquifer or reservoir into which the piping system is installed is a water source for a potable water system.

Note 4: A PE-RT compound will also be listed by PPI's Hydrostatic Stress Board with a minimum Hydrostatic Design Basis (HDB) value of 630 psi at 180°F (82°C), instead of the typical 140°F (60°C) HDB listings for HDPE compounds.

⁶ PE 3608 meets the minimum requirements of ANSI/CSA/IGSHPA C448. Other PE material designation codes listed exceed the minimum requirements.

⁷ Not all material formulations are readily available in all markets and regions. The most common PE-RT materials available at the time of this publication are PE 3608 and PE 4710.

4.4 PP: Polypropylene

There are two grades of polypropylene used for pressure piping materials. Both grades are included in the same product standards.



Figure 8: Example of PP pellets (resin), pipe and fittings

Random copolymerized polypropylene (PP-R) is a high-temperature plastic pressure piping system first used for plumbing and hydronic heating in the 1980s in Europe and introduced to North America in the 2000s. The material known as *polypropylene random copolymer with modified crystallinity & temperature resistance (PP-RCT)* was introduced to North America in the 2010s.

PPI recommends that all PP piping components used for ground-coupled heat exchangers should:

- 4.4.1 Have a Minimum Required Strength (MRS) of 10 MPa (1,450 psi) at 20°C (68°F) per ISO 9080.
- 4.4.2 Be a polypropylene extrusion compound per ASTM F2389 and CSA B137.11.
- 4.4.3 Meet the requirements of NSF/ANSI Standard 358-2.
- 4.4.4 Meet the requirements of NSF/ANSI Standard 61 for open-loop systems, or if the water aquifer or reservoir into which the piping system is installed is a water source for a potable water system.

Note 5: The piping materials listed in 4.1, 4.2, 4.3, and 4.4 are based on the requirements of product standards and codes (i.e. mechanical and geothermal codes) used within USA and Canada. Requirements for piping materials used for geothermal systems in other countries (e.g. Mexico) may differ from the requirements listed within this Technical Note, to comply with local regulations.

5.0 HEADERS AND DISTRIBUTION MANIFOLDS

Most ground source geothermal projects require more than one loop of heat exchange piping, or other style of heat exchanger, in the ground for the required heat transfer capacity. This means that for most installed systems, there are multiple boreholes, horizontal loops, helixes, energy piles, pond loops, etc. Geothermal ground loop systems can range in size from just a few ground heat exchangers (i.e. pipe loops) to hundreds or even thousands.

To connect the various piping loops, header systems and distribution manifolds are utilized. As described in this document, headers and distribution manifolds are somewhat distinct from each other. Headers often have no valves for flow control of the individual ground loops (i.e. valveless), whereas distribution manifolds often have valves for flow control and/or isolation of individual ground loops.

Common materials for headers and distribution manifolds include:

- HDPE: Using the same materials for pipes and fittings, heat-fused or electrofused together using tees, for direct burial in the ground.
- PP: Fabricated on-site or in a factory setting, with tees fused onto larger headers; often valves of the same material are fused into each outlet for control of each loop
- Steel⁸: Fabricated in a factory setting, with tees welded onto larger headers
- Copper alloy (brass)⁸: Fabricated in a factory setting, with outlets joined onto larger headers using threaded or brazed connections

Sections 5.1 and 5.2 will describe headers and distribution manifolds in detail.

5.1 Header Systems Installed in the Ground

The term “header” generally refers to piping configurations that are buried below grade in the earth. Headers may be fabricated in the field using sections of pipes joined to tees and elbows, or may be partially pre-fabricated in a factory before installation at the project site, then buried directly in the ground.

⁸ Distribution manifolds or headers constructed of steel or copper alloy (brass) components must be carefully selected, and are usually not appropriate to be buried in direct contact with the soil due to risk of corrosion. Common techniques for protecting the metal components from naturally corrosive soil and/or damaging chemicals in the soil may include housing the manifold or header in a vault, or wrapping the metal components with self-fusing, silicone tape.

In-ground header systems are typically piped in one of three (3) distinct configurations:

- 5.1.1 Reverse-Return (preferred for balanced flow);
- 5.1.2 Series (generally avoided due to high pressure losses); or
- 5.1.3 Parallel or “Home run” (each ground loop piped individually to a central header or manifold in a collection vault or in the building mechanical room or space).

Valveless in-ground (buried) headers often require designers to employ several pipe diameters in a Reverse–Return layout, stepping-up and stepping-down pipe diameters to direct the fluid flow to be equal to all ground loops, otherwise short circuits can result. Short circuits will receive excessive flow, simultaneously drawing flow from other longer circuits, resulting in an unbalanced system that likely will not meet performance expectations. See **Figure 9** as an example.

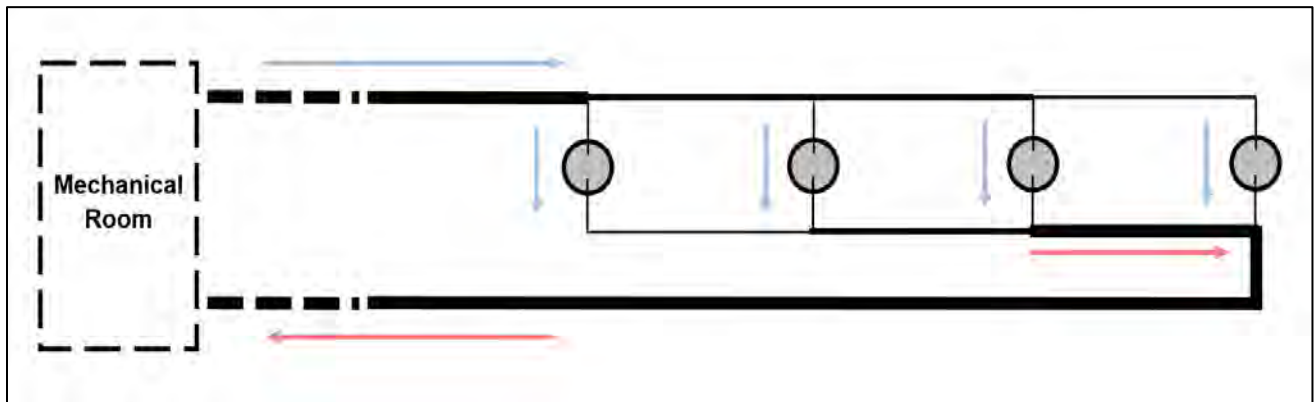

Figure 9: Typical Reverse-Return in-ground (buried) header system employing several pipe diameters to connect four (4) vertical boreholes; flow to be equal through all four. Connection details at tees and elbows not shown (not to scale).

When using valveless headers buried in the ground, designs that balance flows through individual loops or ground heat exchangers are critical. Systems with loop lengths that differ more than 5% in total length from each another may result in unbalanced flows and poor performance, unless other balancing techniques are employed.

Unbalanced header systems, or header systems with a large number of connected individual ground loops, can present significant challenges when the system must be filled with fluid and purged of air. This process often requires specialized high-head and high-velocity purging equipment to be used on-site temporarily for this purpose.

5.2 Distribution Manifold Systems

Distribution manifolds (also called mechanical manifolds) are typically located in building mechanical spaces or in exterior collection vaults, buried in the earth. A distribution manifold typically contains a supply header and a return header, mounted closely together in pairs. When the individual ground loops are connected to such a centralized distribution manifold, then the ground loops are in parallel, also known as home-run.

Larger pipes transfer fluid to and from the supply and return headers of the distribution manifold, respectively, to the heat pump equipment in the mechanical room or space.

Distribution manifolds may be built with individual balancing valves installed on the supply or return header, depending on the type of balancing valve used.

Balancing valves can correct the unbalanced low pressure loss (or head loss) of short circuits simply by adding the correct amount of resistance in the valve itself. This can correct inherently unbalanced systems, to ensure optimal flow through each loop of the ground heat exchanger piping. See **Figure 10** as an example

Shut-off valves are typically installed at each loop or circuit, on both supply and return headers, to allow for complete isolation for purging, repair and maintenance.

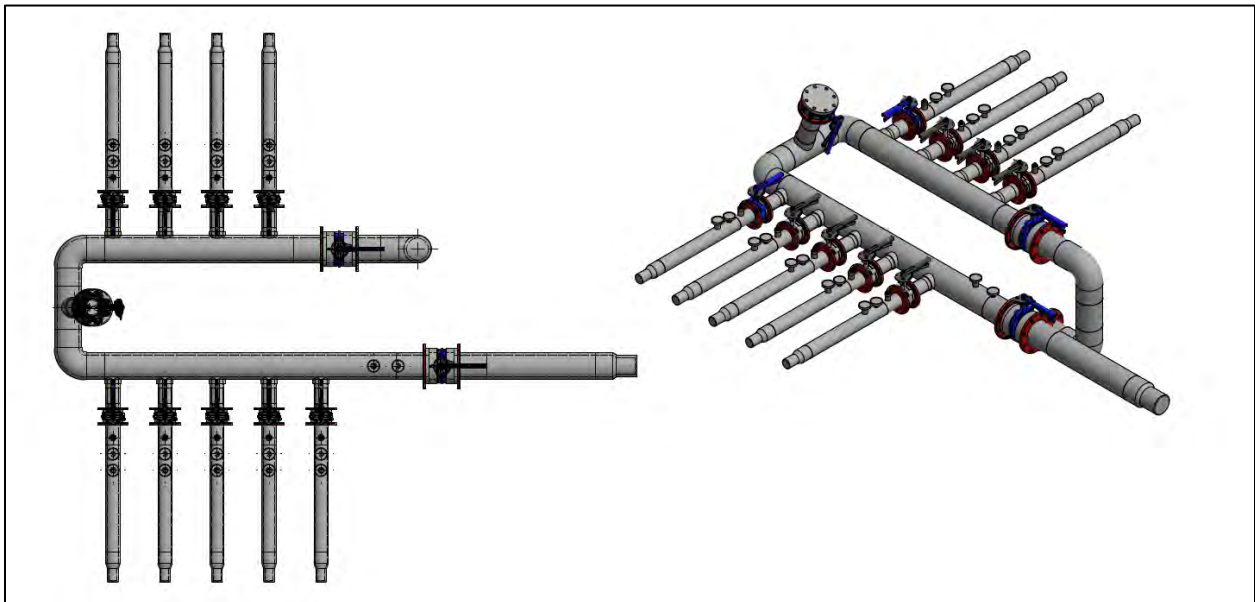

Figure 10: Example of a distribution manifold with shut-off valves on supply and return headers and balancing valves on supply header (two views of the same design)

5.2.1 Collection Vaults

Underground collection vaults are generally employed when building the mechanical space is limited, or the system is very large. Exterior buried collection vaults can be located adjacent to buildings or installed at long distances from buildings, oftentimes hundreds of feet or meters from the mechanical room within the building.

Collection vaults are sometimes made of cast concrete, but the preferred designs of vaults are fabricated from HDPE materials, often using flat sheets and large diameter pipes, welded together as a vertical column or tower, water-tight and safe for access by installers and maintenance crews. Horizontally-oriented designs are used for systems with larger manifolds. See **Figure 11** as an example of a horizontal vault.

The underground collection vault typically contains one or more distribution manifolds, depending on the size of the system. The vault may be centrally located in the midst of many ground heat exchangers, with larger diameter supply and return pipes transferring the heat exchange fluid to the heat pumps in the mechanical space.

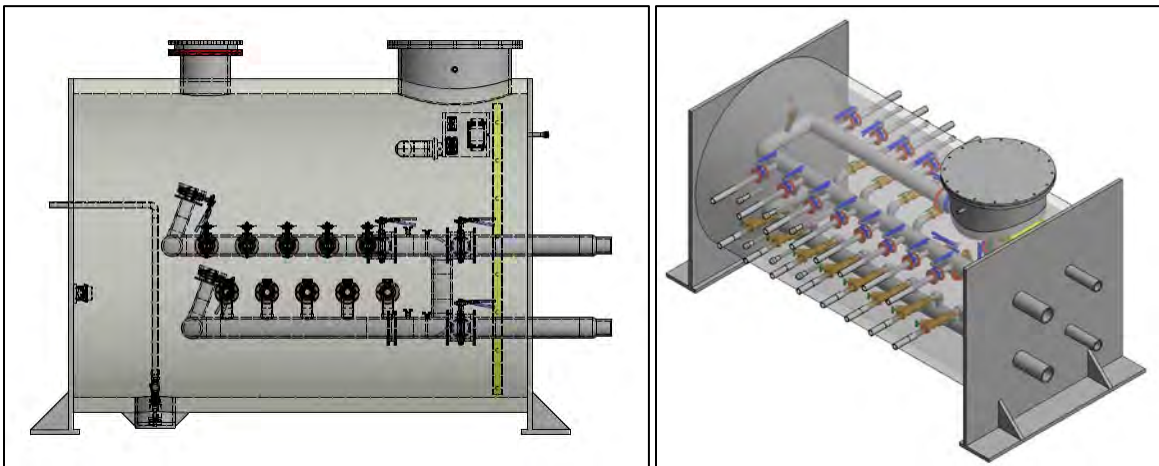

Figure 11: Example of HDPE collection vaults with integrated manifolds (different designs)

6.0 HEAT TRANSFER FLUID

The type of heat transfer fluid or medium can vary, depending on factors such as system design, required thermal performance (and fluid specific heat), pumping performance (viscosity), local regulations, cost, availability, and contractor preference. Potential options include water, brine, diluted ethylene glycol, propylene glycol or methanol.

Designers must ensure that the heat-transfer fluid is compatible with components with which it comes into contact.

In general, plastic piping materials are very resistant to these types of heat transfer fluids, proven through many years of field service. Test methods, such as those found within the NSF Standard 358 series of product certification standards, are available to test and demonstrate the resistance of piping materials to various fluids.

Some fluids may have characteristics that can be dangerous, such as flammability and toxicity to both the environment and humans, if not properly handled, mixed and contained. Contact the heat transfer fluid manufacturer for a safety data sheet (SDS) or materials safety data sheet (MSDS), and for specific information about environmental safety and hazards. Check with local regulations for approvals.

Industry standards, codes and local/state/provincial regulations will often specify which types of heat transfer fluid/s are permitted and prohibited for use in the specific jurisdiction or location. Some jurisdictions require that heat transfer fluids are non-toxic and/or non-flammable. System designers and installers must check local regulations before specifying the heat transfer fluid.

Since the heat transfer capacity or “specific heat” varies from one fluid to the next, this step should be done before sizing the geexchange loop field, as a change in the heat transfer fluid could alter the amount of ground loop piping that is required for the desired heat exchange capacity of the system.

7.0 STANDARDS, CODES and REGULATIONS

Several industry standards, codes and regulations exist to guide industry professionals about the design and installation of closed-loop ground-coupled (geothermal) heating and cooling systems. These documents may be enforced as codes or referenced within codes and regulations for given jurisdictions. Designers, specifiers and installers must verify which standards, codes and regulations apply for the jurisdiction of each system.

A list of the most common standards and codes, and other referenced industry documents, and their sources, follows:

- ANSI/CSA/IGSHPA C448-16 “Design and installation of ground source heat pump systems for commercial and residential buildings” www.csagroup.org
- ANSI/AHRI/ASHRAE ISO Standard 13256-1:1998 (R2012) “Water-source heat pumps - Testing and rating for performance - Part 1: Water-to-air and brine-to-air heat pumps” www.ashrae.org
- ANSI/AHRI/ASHRAE ISO Standard 13256-2:1998 “Water-source heat pumps - Testing and rating for performance - Part 2: Water-to-water and brine-to-water heat pumps”
- ASHRAE 194-2012 “Method of Test for Direct-Expansion Ground-Source Heat Pumps”
- ASTM D2683 “Standard Specification for Socket-Type Polyethylene Fittings for Outside Diameter-Controlled Polyethylene Pipe and Tubing” www.astm.org
- ASTM D3035 “Standard Specification for Polyethylene (PE) Plastic Pipe (DR-PR) Based on Controlled Outside Diameter”
- ASTM D3261 “Standard Specification for Butt Heat Fusion Polyethylene (PE) Plastic Fittings for Polyethylene (PE) Plastic Pipe and Tubing”
- ASTM D3350 “Standard Specification for Polyethylene Plastics Pipe and Fittings Materials”
- ASTM D2837 “Standard Test Method for Obtaining Hydrostatic Design Basis for Thermoplastic Pipe Materials or Pressure Design Basis for Thermoplastic Pipe Products”
- ASTM F1055 “Standard Specification for Electrofusion Type Polyethylene Fittings for Outside Diameter Controlled Polyethylene and Crosslinked Polyethylene (PEX) Pipe and Tubing”
- ASTM F876 “Standard Specification for Crosslinked Polyethylene (PEX) Tubing”
- ASTM F2389 “Standard Specification for Pressure-rated Polypropylene (PP) Piping Systems”
- ASTM F2623 “Standard Specification for Polyethylene of Raised Temperature (PE-RT) SDR 9 Tubing”
- ASTM F2769 “Standard Specification for Polyethylene of Raised Temperature (PE-RT) Plastic Hot and Cold-Water Tubing and Distribution Systems”
- CAN/CSA C448-13 “Design and installation of earth energy systems” www.csagroup.org
- CSA B137.11 “Polypropylene (PP-R) pipe and fittings for pressure applications”
- CSA B137.18 “Polyethylene of raised temperature resistance (PE-RT) tubing systems for pressure applications”
- IAPMO Uniform Solar Energy & Hydronics Code (USEHC) www.iapmo.org
- ICC International Mechanical Code (IMC) www.iccsafe.org
- ICC International Residential Code (IRC)

- International Ground Source Heat Pump Association (IGSHPA) – “Closed-loop/geothermal heat pump systems design and installation standards” www.igshpa.org
- ISO 9080 “Plastics piping and ducting systems - Determination of the long-term hydrostatic strength of thermoplastics materials in pipe form by extrapolation”
- NSF International Standard 358-1 “Polyethylene (HDPE) Pipe and Fittings for Water-Based Ground-Source "Geothermal" Heat Pump Systems” www.nsf.org
- NSF International Standard 358-2 “Polypropylene Pipe and Fittings for Water-Based Ground-Source "Geothermal" Heat Pump Systems”
- NSF International Standard 358-3 “Crosslinked Polyethylene (PEX) Pipe and Fittings for Water-Based Ground-Source "Geothermal" Heat Pump Systems”
- NSF International Standard 358-4 “Polyethylene of Raised Temperature (PE-RT) Pipe and Fittings for Water-Based Ground-Source "Geothermal" Heat Pump Systems”
- PPI TR-3 “Policies and Procedures for Developing Hydrostatic Design Basis (HDB), Hydrostatic Design Stresses (HDS), Pressure Design Basis (PDB), Strength Design Basis (SDB), Minimum Required Strength (MRS) Ratings, and Categorized Required Strength (CRS) for Thermoplastic Piping Materials or Pipe” www.plasticpipe.org
- PPI TR-4, “PPI Listing of Hydrostatic Design Basis (HDB), Strength Design Basis (SDB), Pressure Design Basis (PDB) and Minimum Required Strength (MRS) Ratings for Thermoplastic Piping Materials or Pipe” www.plasticpipe.org

Keywords: Borehole, closed-loop, coaxial piping, concentric, directional drilling, earth energy, energy piles, GHP, GSHP, geoexchange, geothermal, ground source, HDD, inclined drilling, lake loop, open-loop, pond loop, surface water exchange